

Freezer Frost Heave Prevention – RaySol and MI Heating Cable System

Raychem



This step-by-step design guide provides the tools necessary to design an Raychem RaySol self-regulating heating cable system or an Raychem Mineral Insulated heating cable system for freezer frost heave prevention. For other applications or for design assistance, contact your Chemelex representative or call (800) 545-6258. Also, visit our website at chemelex.com.

Table of Contents

INTRODUCTION	2
How to Use this Guide	2
Safety Guidelines	2
Warranty.....	3
SYSTEM OVERVIEW	3
Typical System	4
Self-Regulating Heating Cable Construction.....	6
MI Heating Cable Construction	7
Approvals.....	8
FREEZER FROST HEAVE PREVENTION DESIGN	8
Design Assumptions.....	8
Design Step by Step RaySol and MI Heating Cables in Conduit	9
Step 1 Determine the freezer configuration.....	10
Step 2 Select the heating cable	11
Step 3 Determine the heating cable conduit spacing and freezer load.....	14
Step 4 Determine the heating cable layout and length	15
Step 5 Determine the electrical parameters.....	22
Step 6 Select the connection kits and accessories.....	24
Step 7 Select the control system.....	25
Step 8 Select the power distribution.....	27
Step 9 Complete the Bill of Materials	29
Design Step by Step MI Heating Cables Directly Embedded	30
Step 1 Determine the freezer configuration.....	31
Step 2 Determine heat loss and freezer load	32
Step 3 Select the heating cable, layout and length.....	34
Step 4 Determine the heating cable spacing.....	41
Step 5 Determine the electrical parameters.....	41
Step 6 Select the accessories.....	43
Step 7 Select the control system.....	44
Step 8 Select the power distribution.....	45
Step 9 Complete the Bill of Materials	48
RAYSOL AND MI HEATING CABLE IN CONDUIT FREEZER FROST HEAVE PREVENTION DESIGN WORKSHEET	49
MI CABLES DIRECTLY EMBEDDED FREEZER FROST HEAVE PREVENTION DESIGN WORKSHEET	54

Raychem offers two different heating cable technologies for freezer frost heave prevention: RaySol self-regulating heating cable system and MI heating cable system. Both RaySol and MI heating cables can be installed in conduit. Only MI heating cables can be embedded directly in the subfloor (concrete, sand, or compacted fill).

If your application conditions are different, or if you have any questions, contact your Chemelex representative or call (800) 545-6258.

How to Use this Guide

This design guide presents Raychem's recommendations for designing freezer frost heave prevention systems. It provides design and performance data, electrical sizing information, and heating cable layout suggestions. Following these recommendations will result in a reliable, energy-efficient system.

Follow the design steps in the respective "Design" sections and use the appropriate "RaySol and MI Heating Cable in Conduit Freezer Frost Heave Prevention Design Worksheet" on page 49 and "MI Cables Directly Embedded Freezer Frost Heave Prevention Design Worksheet" on page 54 to document the project parameters that you will need for your project's Bill of Materials.

Other Required Documents

This guide is not intended to provide comprehensive installation instructions. For complete freezer frost heave prevention system installation instructions, please refer to the following additional required documents:

- RaySol Floor Heating and Frost Heave Prevention Installation and Operation Manual (H58138)
- Mineral Insulated Heating Cable Floor Heating and Frost Heave Prevention Installation and Operation Manual (H58137)
- Additional installation instructions are included with the connection kits, thermostats, controllers, and accessories

If you do not have these documents, you can obtain them from our website at chemelex.com/raychem.

For products and applications not covered by this design guide, please contact your Chemelex representative or call (800) 545-6258.

Safety Guidelines

As with any electrical equipment, the safety and reliability of any system depends on the quality of the products selected and the manner in which they are installed and maintained. Incorrect design, handling, installation, or maintenance of any of the system components could damage the system and may result in inadequate performance, overheating, electric shock, or fire. To minimize these risks and to ensure that the system performs reliably, read and carefully follow the information, warnings, and instructions in this guide.



This symbol identifies important instructions or information.



This symbol identifies particularly important safety warnings that must be followed.



WARNING: To minimize the danger of fire from sustained electrical arcing if the heating cable is damaged or improperly installed, and to comply with the requirements of Chemelex, agency certifications, and national electrical codes, ground-fault equipment protection must be used on each heating cable branch circuit. Arcing may not be stopped by conventional circuit protection.

Warranty

Raychem standard limited warranty applies to Raychem Freezer Frost Heave Prevention Systems.



An extension of the limited warranty period to ten (10) years from the date of installation is available, except for the control and distribution systems, if a properly completed online warranty form is submitted within thirty (30) days from the date of installation. You can access the complete warranty on our website at

<https://www.chemelex.com/raychem/support/warranty-information>.

SYSTEM OVERVIEW

Subfreezing temperatures inside cold rooms, freezers, and ice arenas cause heat to be lost from the soil under the floor, even when it is well insulated. As the soil freezes, capillary action draws water into the frozen areas where the water forms a concentrated ice mass. As the ice mass grows, it heaves the freezer floor and columns, causing damage.

Raychem offers two different heating cable technologies for freezer frost heave prevention: RaySol self-regulating heating cable and MI heating cable system. Both RaySol and MI heating cables can be installed in conduit. Only MI heating cables can be embedded directly in the subfloor (sand, compacted fill or concrete). The electrical conduit carrying the heating cable or the directly embedded heating cable is installed in the subfloor under the freezer-floor insulation, as illustrated below. The subfloor layer may be a reinforced concrete slab, a concrete mud slab, a bed of compacted sand, or simply compacted fill.

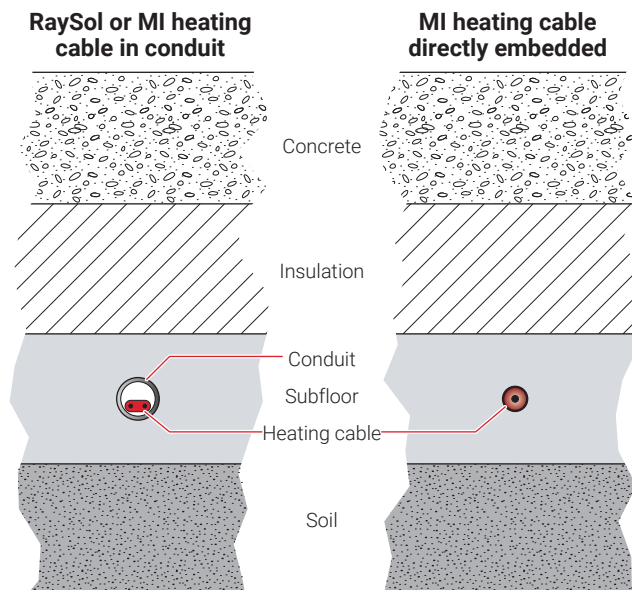

Fig. 1 Typical freezer frost heave installation

The RaySol self-regulating heating cable provides a cut-to-length solution. The backbone of the system is the self-regulating heating cable available for 120 and 208–277 V applications. As Fig. 4 on page 6 indicates, the cable's output is reduced automatically as the subfloor warms, so there is no possibility of failure due to overheating. Since there is no possibility of overheating, RaySol may be operated without thermostatic control. Elements of a RaySol system include the heating cable, termination, splice connections and accessories, controls, power distribution panels, and the tools necessary for a complete installation.

MI heating cable can be used for single-phase and three-phase applications up to 600 V and the cable can be installed in conduit or directly embedded in sand (recommended), concrete, or compacted fill. For directly embedded applications, long cable runs can be accommodated allowing frost heave prevention systems to be designed for large freezers and ice arenas using only a few circuits. MI heating cables are rugged factory-terminated cables (Fig. 6 and Fig. 7) that are engineered to suit your application, power and configuration requirements. Elements of an MI system include the heating cable, accessories, controls, power distribution panels, and the tools for a complete installation.

Typical System

A typical system includes the following:

- RaySol self-regulating heating cable or MI heating cable
- Connection kits (for RaySol only)
- Junction boxes
- Temperature control and power distribution systems

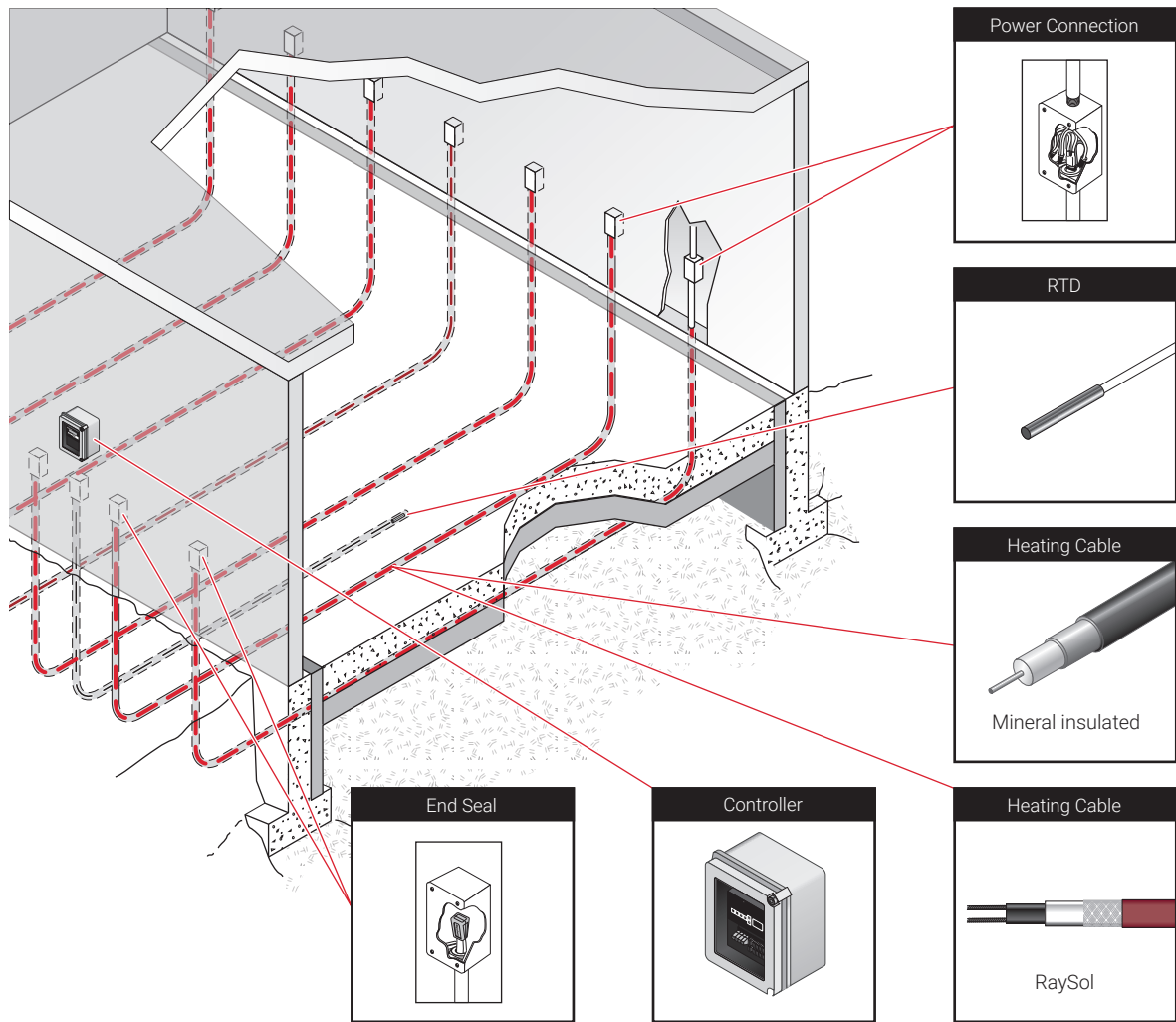

Fig. 2 Typical freezer frost heave system

The following table lists the heating cable, required connection kits, and accessories for a RaySol and MI heating cable systems.

Table 1 Heating Cables and Connection Kits

	Catalog Number	Description
Heating cable	RaySol-1 RaySol-2	120 V 208-277 V
	LSZH jacketed copper sheath MI heating cable	≤600 V
Connection kits for RaySol heating cables	FTC-XC	Power connection and end seal
	RayClic-E	End seal
	FTC-HST-PLUS	Splice (as required – not for use inside conduit)

Self-Regulating Heating Cable Construction

RaySol self-regulating heating cables are comprised of two parallel nickel-coated bus wires in a cross-linked polymer core, a tinned copper braid, and a fluoropolymer outer jacket. These cables are cut to length simplifying the application design and installation.

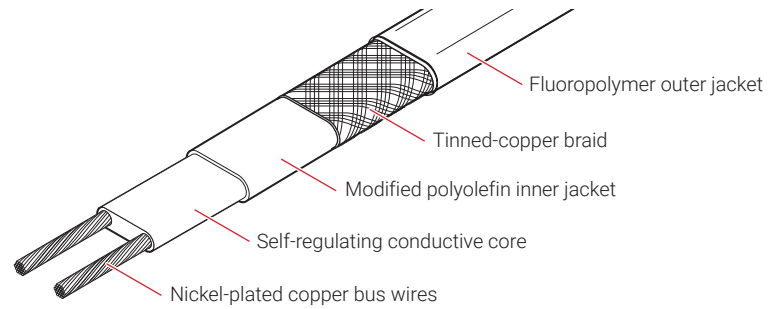

Fig. 3 Typical RaySol heating cable construction

With self-regulating technology, the number of electrical paths between bus wires changes in response to temperature fluctuations. As the temperature surrounding the heater decreases, the conductive core contracts microscopically. This contraction decreases electrical resistance and creates numerous electrical paths between the bus wires. Current flows across these paths to warm the core.

As the temperature rises, the core expands microscopically. This expansion increases electrical resistance and the number of electrical paths decreases. The heating cable automatically reduces its output.

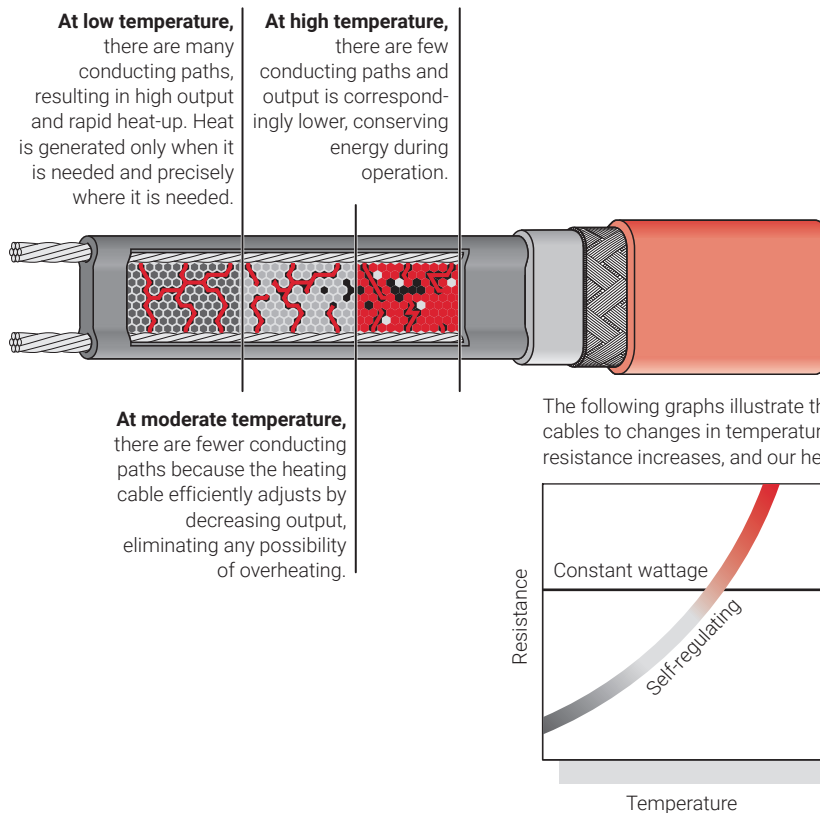

Fig. 4 Self-regulating heating cable technology

MI Heating Cable Construction

MI heating cables used for frost heave prevention applications are comprised of one or two conductors surrounded by magnesium oxide insulation and a solid copper sheath with a Low Smoke Zero Halogen (LSZH) jacket or Alloy 825 stainless steel sheath for directly embedded or in conduit applications.

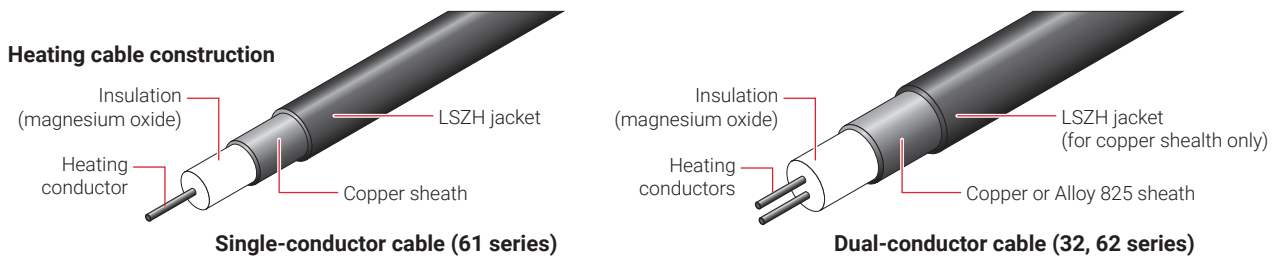

Fig. 5 Typical MI heating cable construction

These heating cables are supplied as complete factory-fabricated assemblies consisting of an MI heating cable that is joined to a section of MI non-heating cold lead and terminated with NPT connectors. Three configurations are available: Type SUA consisting of a looped cable joined to a single 7 ft (2.1 m) cold lead with one 1/2-in NPT connector; Type SUB/FFHP consisting of a single run of cable with a 15 ft (4.6 m) cold lead and a 1/2-in NPT connector on each end; and Type FFHPC consisting of a single run of cable joined to a single 7 ft (2.1 m) cold lead with one 1/2-in NPT connector.

Types SUA and SUB/FFHP heating cables (Fig. 6) are used for directly embedded applications, and Type FFHPC heating cables (Fig. 7) are used for installation in conduit. Type FFHPC heating cables are supplied with a bare copper sheath cold lead and a 3/4-in NPT reversed gland connector and a pulling eye. The reversed gland connector provides a seal for the end of the conduit (see Fig. 13 on page 21).

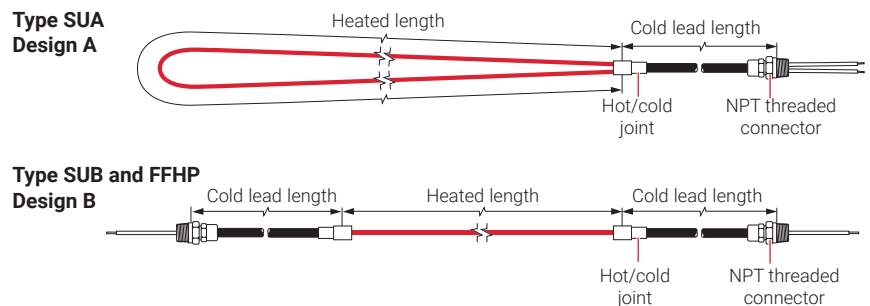

Fig. 6 Configurations for directly embedded installations

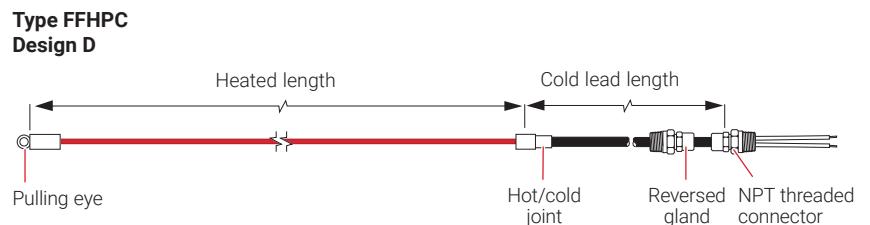

Fig. 7 Configuration for installation in conduit

Raychem offers all the major components necessary for system installation. Details of these components and additional accessories can be found later in this section.

Approvals

Installation of RaySol and MI heating cable systems is governed by national and local electrical codes. Chemelex, the NEC, and the CEC all require the use of ground-fault protection of equipment to reduce the risk of fire caused by damage or improper installation.

RaySol system is UL Listed and CSA Certified for use in nonhazardous locations.



MI system is c-CSA-us Certified and FM Approved for use in nonhazardous locations. FM applies only to the bare copper and stainless steel cable for Freezer Frost Heave installation inside of conduits.



FREEZER FROST HEAVE PREVENTION DESIGN

This section details the steps necessary to design your application. The examples provided in each step are intended to incrementally illustrate the project parameter output for sample designs from start to finish. As you go through each step, use the appropriate RaySol and MI Heating Cable in Conduit Freezer Frost Heave Prevention Design Worksheet 49 and "MI Cables Directly Embedded Freezer Frost Heave Prevention Design Worksheet" on page 54 to document your project parameters, so that by that end of this section, you will have the information you need for your Bill of Materials.

This section contains two major parts:

1. Design Step by Step RaySol and MI Heating Cables in Conduit (see page 9)
2. Design Step by Step MI Heating Cable Directly Embedded (see page 30)

Design Assumptions

When using this guide to design a system you need the following information:

- Size and layout of freezer or ice arena
- Freezer operating temperature
- Insulation R-value
- Supply voltage and phase
- Control recommendations (over-limit thermostat and monitoring)

The information and recommendations in this section are based on the following design assumptions:

- The information in this guide is based on the application of the RaySol and MI heating cables in the subfloor on grade only.
- Any size freezer or cold room operating below 32°F (0°C) may experience frost heaving.
- The heating cable is located in a sub-slab underneath the insulation. (see Fig. 1)
- The heating cable is in conduit embedded in concrete, sand, or soil (or directly embedded if using MI heating cables). If you are using a different medium, contact Chemelex for an analysis.

For products and applications not covered by this design guide, please contact your Chemelex representative or call (800) 545-6258.

Design Step by Step RaySol and MI Heating Cables in Conduit

This section guides you through the steps necessary to design your system using RaySol self-regulating or MI heating cables in conduit.

Your system design requires the following essential steps:

- 1 Determine the freezer configuration
- 2 Select the heating cable
 - A. RaySol heating cable in conduit
 - B. MI heating cable in conduit
- 3 Determine the heating cable conduit spacing and freezer load
- 4 Determine the heating cable layout and length
 - A. RaySol heating cable in conduit
 - B. MI heating cable in conduit
- 5 Determine the electrical parameters
 - A. RaySol heating cable in conduit
 - B. MI heating cable in conduit
- 6 Select the connection kits and accessories
- 7 Select the control system
- 8 Select the power distribution
- 9 Complete the Bill of Materials

The "RaySol and MI Heating Cable in Conduit Freezer Frost Heave Prevention Design Worksheet" on page 49 is included to help you document the project parameters that you will need for your project's Bill of Materials.

Freezer Frost Heave Prevention System Design Steps (in Conduit)
1. Determine the freezer configuration
2. Select the heating cable
3. Determine heating cable conduit spacing and freezer load
4. Determine the heating cable layout and length
5. Determine the electrical parameters
6. Select the connection kits and accessories
7. Select the control system
8. Select the power distribution
9. Complete the Bill of Materials

Step 1 Determine the freezer configuration

Gathering Information

The following information is required to complete the freezer frost heave prevention system design.

- Size and layout of freezer or ice arena
- Freezer operating temperature
- Insulation R-value
- Supply voltage (single-phase)
- Control requirements

Prepare scale drawing

Draw to scale the floor area to be heated. Carefully note the limits of the area to be heated. Show all concrete joints on the drawing and note the location and size of obstacles, such as floor drains, pipe penetrations, conduit runs (if required), columns, fixtures, and voltage supply location.

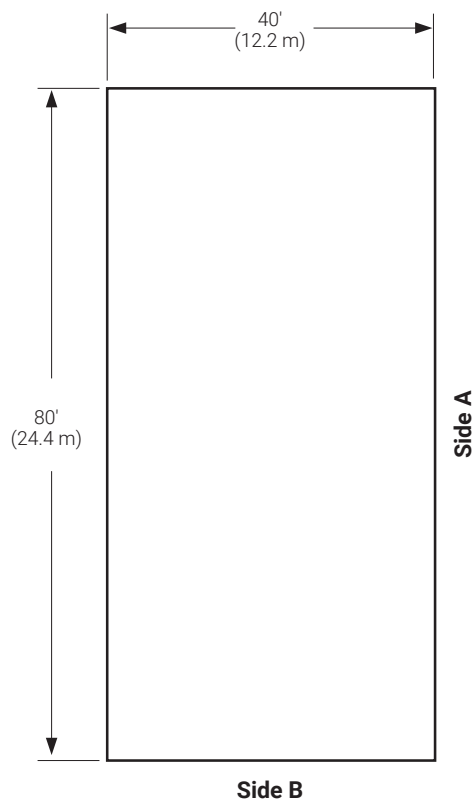

Fig. 8 Typical freezer example

Determine the freezer operating temperature

Determine the temperature at which your freezer operates. If it operates at more than one temperature, or if the operating temperature may be changed in the future, base the spacing selection on the lowest anticipated operating temperature.

Record insulation R-value

The insulation R-value is the thermal resistance of the floor's insulation. Normally the R-value will be printed on the insulation material. If that is not the case, you can calculate it by dividing the insulation thickness in inches by the insulation thermal conductivity.

Example: RaySol and MI heating cables in conduit

Area	80 ft x 40 ft = 3200 ft ² (24.4 m x 12.2 m = 297 m ²)
Freezer operating temperature	-20°F (-29°C)
Insulation R-value	R-40 (40 ft ² ·°F·hr/Btu)
Supply voltage	208 V, single-phase

Freezer Frost Heave Prevention System Design Steps (in Conduit)
1. Determine the freezer configuration
2. Select the heating cable
3. Determine heating cable conduit spacing and freezer load
4. Determine the heating cable layout and length
5. Determine the electrical parameters
6. Select the connection kits and accessories
7. Select the control system
8. Select the power distribution
9. Complete the Bill of Materials

Step 2 Select the heating cable

The heating cable you select will depend on your system:

- A. RaySol heating cable in conduit
- B. MI heating cable in conduit

Step 2A: For RaySol heating cable in conduit

Select the heating cable based on the operating voltage determined in Step 1. For 120 volts, select RaySol-1; for 208/240/277 V, select RaySol-2.

Table 2 RaySol Heating Cable

Supply voltage	Catalog number
120 V	RaySol-1
208–277 V	RaySol-2

Example: RaySol heating cables in conduit

Supply voltage	208 V (from Step 1)
Catalog number	RaySol-2

Step 2B: For MI heating cable in conduit

Select the heating cable from Table 3 based on the operating voltage from Step 1 and the freezer length. The freezer length must be equal to or within the minimum and maximum length shown in the "Freezer length" column. For the example in Fig. 8, under the appropriate voltage (208 V), select the heating cable from the "Freezer length" column with a Minimum (80 ft/24.4 m) and Maximum (84 ft/25.6 m) length that encompasses the freezer length (80 ft/24.4 m) required.

If your freezer is longer than 104 ft (32 m), or the supply voltage is different than those listed, or the system will be powered from a three-phase supply, please contact your Chemelex representative or call (800) 545- 6258 for a custom design.

If it is not possible to install the conduit runs parallel to the freezer length (Side A), then select the heating cable based on the freezer width (Side B).

Table 3 Selection Table for MI Heating Cables in Conduit

Catalog number	Freezer length				Heated length		Power output	Heating cable current (A) ¹
	Min (ft)	Max (ft)	Min (m)	Max (m)	(ft)	(m)	(W)	
120 V								
FFHPC1	15	19	4.6	5.8	15	4.6	105	0.9
FFHPC2	20	24	6.1	7.3	20	6.1	120	1.0
FFHPC3	25	29	7.6	8.8	25	7.6	145	1.2
FFHPC4	30	34	9.1	10.4	30	9.1	175	1.5
FFHPC5	35	39	10.7	11.9	35	10.7	240	2.0
FFHPC6	40	44	12.2	13.4	40	12.2	315	2.6
FFHPC7	45	49	13.7	14.9	45	13.7	280	2.3
FFHPC8	50	54	15.2	16.5	50	15.2	360	3.0
FFHPC9	55	59	16.8	18.0	55	16.8	330	2.8
FFHPC10	60	64	18.3	19.5	60	18.3	400	3.3
FFHPC11	65	69	19.8	21.0	65	19.8	370	3.1
FFHPC12	70	74	21.3	22.6	70	21.3	515	4.3
FFHPC13	75	79	22.9	24.1	75	22.9	480	4.0
FFHPC14	80	84	24.4	25.6	80	24.4	450	3.8
FFHPC15	85	89	25.9	27.1	85	25.9	565	4.7
FFHPC16	90	94	27.4	28.7	90	27.4	535	4.5
FFHPC17	95	99	29.0	30.2	95	29.0	750	6.3
FFHPC18	100	104	30.5	31.7	100	30.5	720	6.0
208 V								
FFHPC19	25	29	7.6	8.8	25	7.6	155	0.7
FFHPC20	30	34	9.1	10.4	30	9.1	190	0.9
FFHPC21	35	39	10.7	11.9	35	10.7	205	1.0
FFHPC22	40	44	12.2	13.4	40	12.2	270	1.3
FFHPC23	45	49	13.7	14.9	45	13.7	350	1.7
FFHPC24	50	54	15.2	16.5	50	15.2	315	1.5
FFHPC25	55	59	16.8	18.0	55	16.8	390	1.9
FFHPC26	60	64	18.3	19.5	60	18.3	425	2.0
FFHPC27	65	69	19.8	21.0	65	19.8	390	1.9
FFHPC28	70	74	21.3	22.6	70	21.3	540	2.6
FFHPC29	75	79	22.9	24.1	75	22.9	505	2.4
FFHPC30	80	84	24.4	25.6	80	24.4	475	2.3
FFHPC31	85	89	25.9	27.1	85	25.9	635	3.1
FFHPC32	90	94	27.4	28.7	90	27.4	600	2.9
FFHPC33	95	99	29.0	30.2	95	29.0	570	2.7
FFHPC34	100	104	30.5	31.7	100	30.5	720	3.5

Table 3 Selection Table for MI Heating Cables in Conduit

Catalog number	Freezer length				Heated length		Power output (W)	Heating cable current (A) ¹
	Min (ft)	Max (ft)	Min (m)	Max (m)	(ft)	(m)		
277 V								
FFHPC35	30	34	9.1	10.4	30	9.1	230	0.8
FFHPC36	35	39	10.7	11.9	35	10.7	240	0.9
FFHPC37	40	44	12.2	13.4	40	12.2	255	0.9
FFHPC38	45	49	13.7	14.9	45	13.7	285	1.0
FFHPC39	50	54	15.2	16.5	50	15.2	380	1.4
FFHPC40	55	59	16.8	18.0	55	16.8	350	1.3
FFHPC41	60	64	18.3	19.5	60	18.3	465	1.7
FFHPC42	65	69	19.8	21.0	65	19.8	430	1.6
FFHPC43	70	74	21.3	22.6	70	21.3	400	1.4
FFHPC44	75	79	22.9	24.1	75	22.9	500	1.8
FFHPC45	80	84	24.4	25.6	80	24.4	480	1.7
FFHPC46	85	89	25.9	27.1	85	25.9	530	1.9
FFHPC47	90	94	27.4	28.7	90	27.4	500	1.8
FFHPC48	95	99	29.0	30.2	95	29.0	700	2.5
FFHPC49	100	104	30.5	31.7	100	30.5	670	2.4

¹ Single-phase current shown

Tolerance on cable length is -0% to +1%.

All heating cables supplied with 3/4-in NPT reversed gland and pulling eye.

Type FFHPC cables supplied with 7 ft (2.1 m) long cold lead.

Example: MI heating cables in conduit

Supply voltage	208 V
Freezer (Side A) length	80 ft (24.4 m) (from Step 1)
Catalog number	FFHPC30
Power output	475 W

Freezer Frost Heave Prevention System Design Steps (in Conduit)
1. Determine the freezer configuration
2. Select the heating cable
3. Determine heating cable conduit spacing and freezer load
4. Determine the heating cable layout and length
5. Determine the electrical parameters
6. Select the connection kits and accessories
7. Select the control system
8. Select the power distribution
9. Complete the Bill of Materials

Step 3 Determine the heating cable conduit spacing and freezer load

For RaySol and MI cable Systems

In this step you will determine the conduit spacing, and freezer loads for the RaySol or MI heating cable systems. Use the freezer operating temperature and the floor insulation R-value to select the correct spacing shown in Table 4. If your calculated R-value or freezer operating temperature does not match the values in the table, use the values that give the closer spacing.

Within each cell in Table 4, there are two numbers: conduit spacing and freezer load. Freezer load is the additional cooling load imposed on the cooling system by the freezer frost heave prevention heating cable. It is the heat transferred through the insulation into the freezer, expressed in W/ft² (W/m²) of floor area.

Table 4 RaySol and MI Conduit Spacing and Freezer Load

Freezer operating temperature			Floor insulation R-value (ft ² ·°F·hr/Btu)			
			R-10	R-20	R-30	R-40
30°F (-1°C)	Conduit spacing	in (cm)	96 (244)	96 (244)	96 (244)	96 (244)
	Freezer load	W/ft ² (W/m ²)	0.7 (8)	0.4 (4)	0.3 (3)	0.2 (2)
20°F (-7°C)	Conduit spacing	in (cm)	81 (206)	96 (244)	96 (244)	96 (244)
	Freezer load	W/ft ² (W/m ²)	0.8 (9)	0.5 (5)	0.3 (3)	0.3 (3)
10°F (-12°C)	Conduit spacing	in (cm)	63 (160)	96 (244)	96 (244)	96 (244)
	Freezer load	W/ft ² (W/m ²)	1.0 (11)	0.6 (6)	0.4 (4)	0.3 (3)
0°F (-18°C)	Conduit spacing	in (cm)	51 (130)	84 (213)	96 (244)	96 (244)
	Freezer load	W/ft ² (W/m ²)	1.2 (13)	0.8 (9)	0.5 (5)	0.4 (4)
-10°F (-23°C)	Conduit spacing	in (cm)	42 (107)	72 (183)	96 (244)	96 (244)
	Freezer load	W/ft ² (W/m ²)	1.5 (16)	0.8 (9)	0.6 (6)	0.5 (5)
-20°F (-29°C)	Conduit spacing	in (cm)	36 (91)	63 (160)	87 (221)	96 (244)
	Freezer load	W/ft ² (W/m ²)	1.8 (19)	1.0 (11)	0.6 (6)	0.5 (5)
-30°F (-34°C)	Conduit spacing	in (cm)	33 (84)	57 (145)	78 (198)	93 (236)
	Freezer load	W/ft ² (W/m ²)	2.0 (22)	1.1 (12)	0.8 (9)	0.6 (6)
-40°F (-40°C)	Conduit spacing	in (cm)	30 (76)	51 (130)	69 (175)	84 (213)
	Freezer load	W/ft ² (W/m ²)	2.3 (25)	1.2 (13)	0.8 (9)	0.7 (8)

Example: RaySol and MI heating cables in conduit

Freezer operating temperature	-20°F (-29°C) (from Step 1)
Insulation R-value	R-40 (40 ft ² ·°F·hr/Btu) (from Step 1)
Conduit spacing	96 in (244 cm)
Freezer load	0.5 W/ft² (5 W/m²)

Freezer Frost Heave Prevention System Design Steps (in Conduit)
1. Determine the freezer configuration
2. Select the heating cable
3. Determine heating cable conduit spacing and freezer load
4. Determine the heating cable layout and length
5. Determine the electrical parameters
6. Select the connection kits and accessories
7. Select the control system
8. Select the power distribution
9. Complete the Bill of Materials

Step 4 Determine the heating cable layout and length

Step 4A For RaySol heating cable in conduit

Estimate number of conduit runs

To calculate the number of conduit runs and heating cable length from your scaled drawing, refer to Fig. 9 and Fig. 10.

Define Side "A" as the side that is parallel to the conduit runs. Side "A" cannot be greater than the maximum circuit length for RaySol (Table 5).

Define Side "B" as the side that is perpendicular to the conduit runs. Refer to Fig. 9 and Fig. 10 for examples of Side A and Side B.

Two basic types of heating cable layouts are used:

1. The hairpin layout (Fig. 9) is used both in smaller freezers where it results in material and labor savings over the straight run layout (Fig. 10), and in other freezers where only one wall of the freezer is accessible for mounting junction boxes.
2. The straight run layout (Fig. 10) is used when the freezer dimension exceeds one-half the maximum heating cable circuit length (insufficient heating cable allowed for a run down and back).

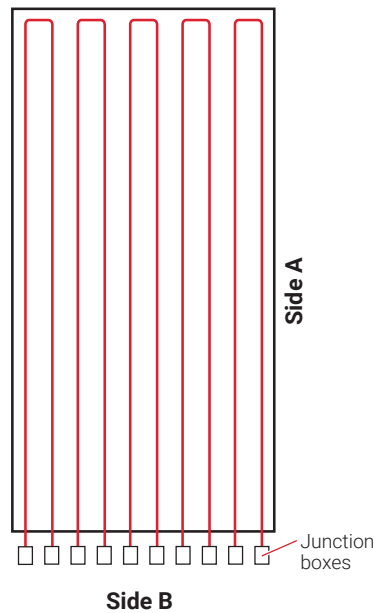

Fig. 9 Hairpin layout

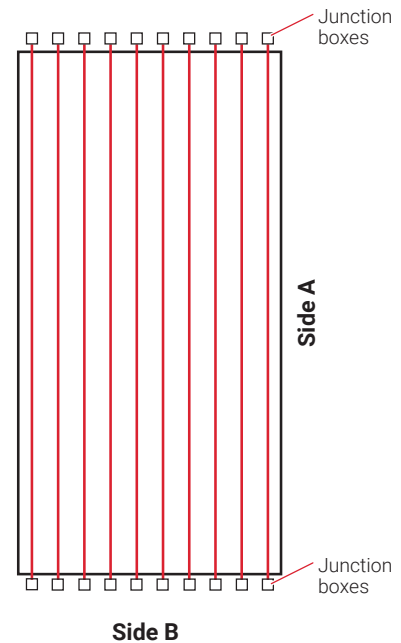

Fig. 10 Straight run layout

Calculate the number of estimated conduit runs as follows:

$$\begin{aligned}
 \text{Estimated number of conduit runs} &= \frac{\text{Side B (ft)} \times 12}{\text{Conduit spacing (in)}} \\
 &= \frac{\text{Side B (m)} \times 100}{\text{Conduit spacing (cm)}}
 \end{aligned}$$

Round the estimated number of conduit runs to the next larger whole number. For example, if the result is 7.4, then 8 conduit runs are required. It may be necessary to recalculate the conduit spacing following this step.

Example: RaySol heating cables in conduit

Side B length 40 ft (12.2 m) (from Step 1)
 Conduit spacing 96 in (244 cm) (from Step 3)
 Number of conduit runs
 Side B x 12 / spacing (in) $40 \text{ ft} \times 12 / 96 \text{ in} = 5$
 Side B x 100 / spacing (cm) $12.2 \text{ m} \times 100 / 244 \text{ cm} = 5$

Estimate the heating cable length required for conduit runs

Multiply the conduit length (Side A) by the number of conduit runs to determine the length of heating cable required for the freezer area.

Heating cable length = Conduit length (Side A) x number of conduit runs

Example: RaySol heating cables in conduit (continued)

Heating cable length required $80 \text{ ft} (24.4 \text{ m}) \times 5 = 400 \text{ ft} (122 \text{ m})$

Determine the maximum circuit length for the heating cable length and layout

For the appropriate supply voltage, use Table 5 to select the maximum circuit length which is closest to, but greater than the length calculated. Select the smallest appropriate circuit breaker size.

Table 5 RaySol Maximum Circuit Lengths in Feet (Meters)

Supply voltage	120 V		208 V		240 V		277 V	
Circuit breaker size (A)	ft	m	ft	m	ft	m	ft	m
15	180	54.9	305	93.0	335	102.1	375	114.3
20	240	73.2	410	125.0	450	137.2	500	152.4
30	240	73.2	410	125.0	450	137.2	500	152.4
40	240	73.2	410	125.0	450	137.2	500	152.4

If the heating cable length required is greater than the maximum circuit length, multiple circuits must be used.

When Side A x 2 is less than or equal to the maximum circuit length, then the conduit run can be looped into the hairpin layout (Fig. 9). In a hairpin configuration, when you have an odd number of conduit runs, one run will be a straight run as shown in Fig. 11.

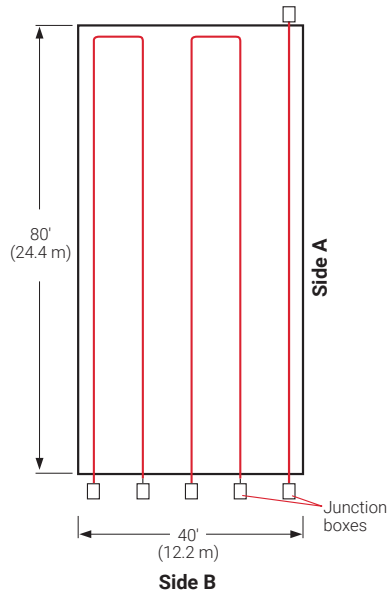

Fig. 11 Layout for example (two hairpins and one straight run)

Example: RaySol heating cables in conduit (continued)

Heating cable length required	400 ft (122 m)
Supply voltage	208 V (from Step 1)
Maximum circuit length	410 ft (125 m) (from Table 5)
Number of circuits	1
Power supply	One 20 A circuit breaker Run in two hairpin loops and one straight run (see Fig. 11)

Ground-Fault Protection

A 30-mA ground-fault protection device (GFPD) must be used to provide protection from arcing or fire, and to comply with warranty requirements, agency certifications, and national electrical codes. If the heating cable is improperly installed, or physically damaged, sustained arcing or fire could result. If arcing does occur, the fault current may be too low to trip conventional circuit breakers.

Determine additional heating cable allowance

Additional heating cable is required to make power connections and to route the circuits to junction boxes. This extra heating cable shall not be considered when determining the maximum heating cable length for circuit breaker sizing. In order to estimate the total heating cable length, you will need to take the heating cable length you already calculated, and then add heating cable allowances, as follows:

Estimated total heating cable length = Required heating cable + End allowances + Connection kit allowances

Table 6 RaySol Additional Heating Cable Allowance

Heating cable allowance	Description	Hairpin layout	Straight run layout
End allowances	From end of conduit to junction box	8 ft per hairpin conduit	8 ft per straight run conduit
Connection kit allowances	Required to assemble the connection kit	4 ft per kit	4 ft per kit

The end allowance is the length of heating cable installed in protective conduit between the heated floor and the power connection junction box. The connection kit allowance (usually 2 ft per end) is the length of heating cable inside the power connection junction box.

Example: RaySol heating cables in conduit (continued)

Heating cable length required	400 ft (122 m)
End allowance	2 hairpin runs = 16 ft (4.9 m) 1 straight run = 8 ft (2.4 m)
Connection kit allowance	2 hairpin runs (2 FTC-XC kits) = 8 ft (2.4 m) 1 straight run (1 FTC-XC kit) = 4 ft (1.2 m)
Total heating cable allowance	[16 ft (4.9 m) + 8 ft (2.4 m)] + [8 ft (2.4 m) + 4 ft (1.2 m)] = 36 ft (11 m)
Total heating cable length required	400 ft (122 m) + 36 ft (11 m) = 436 ft (133 m) of RaySol-2

Locate the junction boxes for a RaySol heating cable system

The heating cable connects to the branch circuit wiring in a junction box using an Raychem FTC-XC power connection and end seal kit. The heating cable is routed from the subfloor to a junction box located above grade through protective conduit. In most freezer frost heave prevention applications, separate junction boxes are used for the power connection and end seal.

Lay out heating cable runs, circuits, and junction boxes

After determining the approximate total length of heating cable, the number of circuits, and the junction box location, do a trial layout. In making the trial layout, follow these recommendations:

- Start and end each circuit in a junction box.
- Do not design more than one run of heating cable per conduit.
- Arrange the conduit so it uniformly covers the area to be heated.
- Maintain the design conduit spacing within 4 in (10 cm).
- Do not extend the heating cable beyond the room or area in which it originates.
- Do not cross expansion or other subfloor joints.
- Do not route the conduit closer than 4 in (10 cm) to the edge of the subfloor, drains, anchors, or other material in the concrete.
- Do not exceed the maximum circuit length allowed on a branch circuit breaker as given in Table 5.
- The maximum length of heating cable that can be pulled through conduit is 500 feet (150 m). The maximum total degree of conduit turn is 360 degrees.
- When the combined lengths of two or more circuit runs are less than the maximum circuit length allowed, these runs can be combined in parallel on one circuit breaker.

Record circuit information

Reconfigure the trial circuit layout until the design meets all of the previous recommendations. Assign each circuit to a circuit breaker in a specific panel board and record each circuit length.

Step 4B For MI heating cable in conduit

Estimate number of conduit runs

MI cables in conduit can only be installed using the straight run layout shown in Fig. 12.

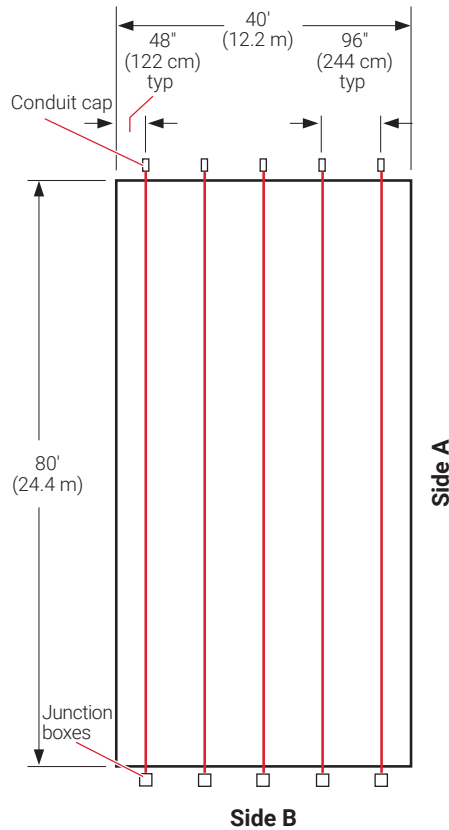

Fig. 12 Layout for straight run example

To calculate the number of conduit runs from your scaled drawing, refer to Fig. 12, and calculate as follows:

$$\begin{aligned} \text{Estimated number of conduit runs} = & \frac{\text{Side B (ft)} \times 12}{\text{Conduit spacing (in)}} \\ & \frac{\text{Side B (m)} \times 100}{\text{Conduit spacing (cm)}} \end{aligned}$$

Round the estimated number of conduit runs to the next larger whole number. For example, if the result is 7.4, then 8 conduit runs are required. It may be necessary to recalculate the conduit spacing following this step.

Note: If the heating cable was selected using the freezer width (Side B) in Step 2, use Side A in the above formula.

Example: MI heating cables in conduit

Side B length	40 ft (12.2 m) (from Step 1)
Conduit spacing	96 in (244 cm) (from Step 3)
Number of conduit runs	
Side B x 12 / spacing (in)	$40 \text{ ft} \times 12 / 96 \text{ in} = 5$
Side B x 100 / spacing (cm)	$12.2 \text{ m} \times 100 / 244 \text{ cm} = 5$

Determine the number of MI heating cables

Number of heating cables required = Number of conduit runs

Example: MI heating cables in conduit (continued)

Heating cable	FFHPC30 (from Step 2)
Number of conduit runs	5
Number of heating cables required	5

Locate the junction boxes for an MI heating cable system

MI heating cables are factory terminated with 7 ft (2.1 m) long non-heating cold leads, making it possible to connect two or three heating cables to a single junction box. An MIJB-864-A may be used where two heating cables are connected in parallel. A junction box is only required for the power connection end.

Lay out the MI heating cable runs, circuits, and junction boxes

After determining the number of heating cables required, the number of circuits, and the junction box locations, do a trial layout. In making the trial layout, follow these recommendations:

- The conduits must be laid out in straight runs as shown in Fig. 12.
- Where cable lengths exceed 50 ft (15.2 m), the conduit must be accessible from both ends to allow long runs of cable to be pulled into the conduit.
- If it is necessary to stub-up the ends of the conduit, use a minimum 12 in (30 cm) radius as shown in Fig. 13.
- Arrange the conduits so that they uniformly cover the area to be heated.
- Maintain the design conduit spacing within 4 in (10 cm).
- Do not cross expansion or other subfloor joints.
- Do not route the conduit closer than 4 in (10 cm) to the edge of the subfloor, drains, anchors, or other material in the concrete.

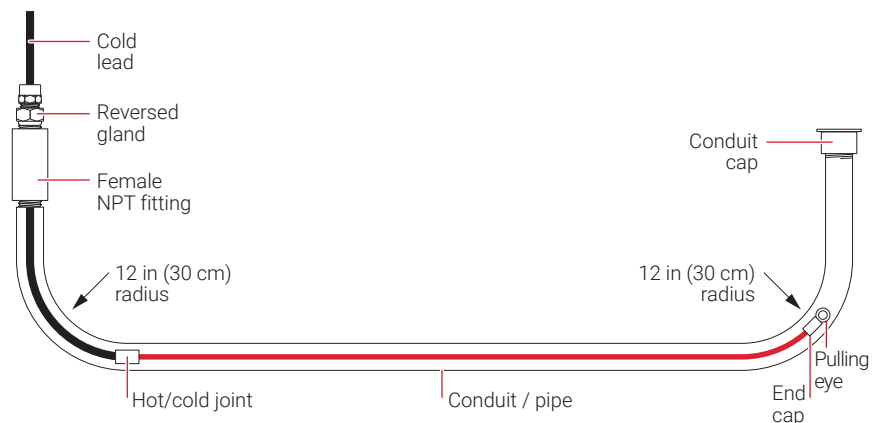

Fig. 13 Installation where conduit ends stub-up

Freezer Frost Heave Prevention System Design Steps (in Conduit)
1. Determine the freezer configuration
2. Select the heating cable
3. Determine heating cable conduit spacing and freezer load
4. Determine the heating cable layout and length
5. Determine the electrical parameters
6. Select the connection kits and accessories
7. Select the control system
8. Select the power distribution
9. Complete the Bill of Materials

Step 5 Determine the electrical parameters

5A For RaySol heating cable in conduit

Determine number of circuits

For RaySol, the circuit breaker sizing was determined in Step 4 using Table 5. Record the number and ratings of the circuit breakers to be used on the worksheet.

A 30-mA ground-fault protection device (GFPD) must be used to provide protection from arcing or fire, and to comply with warranty requirements, agency certifications, and national electrical codes. If the heating cable is improperly installed, or physically damaged, sustained arcing or fire could result. If arcing does occur, the fault current may be too low to trip conventional circuit breakers.

⚠ WARNING: To minimize the danger of fire from sustained electrical arcing if the heating cable is damaged or improperly installed, and to comply with the requirements of Chemelex, agency certifications, and national electrical codes, ground-fault equipment protection must be used on each heating cable branch circuit. Arcing may not be stopped by conventional circuit protection.

Determine transformer load

The total transformer load is the sum of the loads on all the circuit breakers in the system.

Calculate the Circuit Breaker Load (CBL) as:

$$\text{CBL (kW)} = \frac{\text{Circuit breaker rating (A)} \times 0.8 \times \text{Supply voltage}}{1000}$$

Calculate the Total Transformer Load as follows:

$$\text{Total Transformer Load (kW)} = \text{CBL}_1 + \text{CBL}_2 + \text{CBL}_3 + \dots + \text{CBL}_N$$

Example: RaySol heating cables in conduit

Circuit breaker size	One 20 A circuit (from Step 4)
Supply voltage	208 V (from Step 1)
Circuit breaker load	$(20 \text{ A} \times 0.8 \times 208) / 1000 = 3.3 \text{ kW}$
Total transformer load	3.3 kW

5B For MI heating cable in conduit

For MI heating cable, the power output and current draw is shown in Table 3. Heating cables may be individually connected to circuit breakers, but to reduce the number of circuits, cables may be connected in parallel. When connecting heating cables in parallel, total the individual heating cable currents to 80% of the circuit breaker rating.

Determine number of circuits

Refer to Table 3 to determine the Amps for the selected heating cable. Next, calculate the total Amps to determine the circuit breaker requirements, as follows:

Total Amps = Amps per cable x Number of heating cables required

From the Total Amps, determine the most appropriate circuit breaker size and number of circuit breakers.

A 30-mA ground-fault protection device (GFPD) must be used to provide protection from arcing or fire, and to comply with warranty requirements, agency certifications, and national electrical codes. If the heating cable is improperly installed, or physically damaged, sustained arcing or fire could result. If arcing does occur, the fault current may be too low to trip conventional circuit breakers.

 **WARNING:** To minimize the danger of fire from sustained electrical arcing if the heating cable is damaged or improperly installed, and to comply with the requirements of Chemelex, agency certifications, and national electrical codes, ground-fault equipment protection must be used on each heating cable branch circuit. Arcing may not be stopped by conventional circuit protection.

Determine transformer load

The total transformer load is the sum of the loads in the system. Calculate the Total Transformer Load as follows:

$$\text{Transformer load (kW)} = \frac{\text{Cable}_1 \text{ (W)} + \text{Cable}_2 \text{ (W)} + \text{Cable}_3 \text{ (W)} \dots + \text{Cable}_N \text{ (W)}}{1000}$$

Example: MI heating cables in conduit

Amps/cable	2.3 A (from Table 3)
Total Amps	2.3 A x 5 = 11.5 A (5 cables wired in parallel on one circuit)
Circuit breaker size	15 A circuit breaker, 80% loading 12 A
Number of circuit breakers	1

Cable power output	475 W (from Step 2)
Number of cables	5 (from Step 4)
Total Transformer load	(475 W x 5) / 1000 = 2.4 kW

Record the number and ratings of the circuit breakers to be used and total transformer load on the worksheet.

Step 6 Select the connection kits and accessories

For RaySol systems, determine the number of junction boxes, power connections, end seals and splice kits required.

- Hairpin and straight layouts have one junction box per conduit end (see Fig. 9 and Fig. 10).



For MI systems, determine the number of junction boxes required.

- Straight run layout has one junction box per conduit run (see Fig. 12 for MI cable).

Select Junction Box

For RaySol and MI cable, use a UL Listed and/or CSA Certified junction box that is suitable for the location. Use a box with minimum internal volume of 16 cubic inches if the box is metallic and 19 cubic inches if the box is not metallic. Fiberglass junction boxes, such as the MIJB-864-A, are recommended for MI cable.

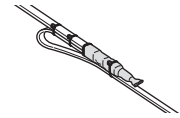
Table 7 Connection Kits and Accessories

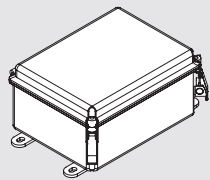
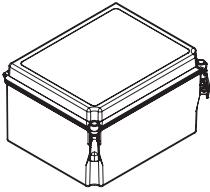
	Catalog number	Description	Standard packaging	Usage
RaySol Connection Kits				
	FTC-XC	Power connection and end seal. (Junction box not included)	1	1 per conduit run
	FTC-HST-PLUS	Low-profile splice/tee	2	As required (for use inside intermediate pull box or cable tray)
	RayClic-E	Extra end seal	1	Replacement end seal
Accessories				
	MIJB-864-A	Junction box with pre-drilled earth plate for use with MI heating units. Typical uses - Power, splice and end box for three-phase systems. Hazardous locations: CID2 Groups B, C and D. Maximum operating voltage 600Vac. Maximum 35A per terminal, rated 18AWG to 6AWG, Type 4X. Entries: Up to 8 x 1/2" and 3 x 3/4". Power cable gland and hubs not included. Two mounting brackets (MBRP-B) and two pipe straps must be ordered separately for installation. Enclosure dimensions: 8" x 6" x 4" (200 x 150 x 100 mm).	1	For MI systems only
	MIJB-1086-B	Junction box with pre-drilled earth plate for use with MI heating units. Accommodates up to 7 outgoing heating cables and one incoming power cable. It can also be used as a marshalling box - one incoming power cable and 5 outgoing power cables. Typical uses - Power or marshalling, splice and end box for three-phase systems. Hazardous locations: CID2 Groups B, C and D. Maximum operating voltage 600Vac. Maximum 35A per terminal, rated 18AWG to 6AWG, Type 4X.	1	For MI systems only

	Catalog number	Description	Standard packaging	Usage
		<p>Entries: Up to 11 x ½" and 8 x ¾". Power cable gland and hubs not included. Two mounting brackets (MBRP-B) and two pipe straps must be ordered separately for installation. Order a separate MIJB-LPWR-KIT for #2 or #4AWG power cable to downsize to #6AWG (35A).</p> <p>Enclosure dimensions: 10" x 8" x 6" (250 x 200 x 150 mm).</p>		

Example: RaySol heating cables in conduit

Power connection and end seal kit	FTC-XC
Quantity	3
Junction box	Contractor supplied
Quantity	6

Example: MI heating cables in conduit

Junction box	MIJB-864-A
Quantity	5

Freezer Frost Heave Prevention System Design Steps (in Conduit)
1. Determine the freezer configuration
2. Select the heating cable
3. Determine heating cable conduit spacing and freezer load
4. Determine the heating cable layout and length
5. Determine the electrical parameters
6. Select the connection kits and accessories
7. Select the control system
8. Select the power distribution
9. Complete the Bill of Materials

Step 7 Select the control system

The following control systems are suitable for both RaySol and MI heating cable frost heave protection systems. For MI cable, a temperature controller must be used to maintain the subfloor temperature at 40°F (5°C). For RaySol or MI heating cable installations where temperature control and temperature monitoring is desired, an Raychem C910-485 or ACS-30 controller is recommended.



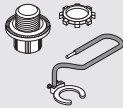

Table 8 Temperature Control Options

Features	ECW-GF	C910-485 ²	ACS-30
Number of heating cable circuits	Single	Single	Multiple
Sensor	Thermistor	RTD ¹	See data sheet
Sensor length	25 ft	Varies	"
Set point range	32°F to 200°F (0°C to 93°C)	-0°F to 200°F (-18°C to 93°C)	"
Enclosure	Type 4X	Type 4X	"
Deadband	2°F to 10°F (2°C to 6°C)	1°F to 10°F (1°C to 6°C)	"
Enclosure limits	-40°F to 140°F (-40°C to 60°C)	-40°F to 140°F (-40°C to 60°C)	"
Switch rating	30 A	30 A	"
Switch type	DPST	DPST	"
Electrical rating	100-277 V	100-277 V	"
Approvals	c-UL-us	c-CSA-us	"
Ground-fault protection	30 mA fixed	20 mA to 100 mA (adjustable)	"
Alarm outputs			
AC relay	2 A at 277 Vac	100-277 V, 0.75 A max.	"
Dry contact relay	2 A at 48 Vdc	48 Vac/dc, 500 mA max.	"

¹ Ordered separately

² The C910-485 is available to provide RS-485 communication capability. Connect to the BMS using ProtoNode multi-protocol gateways

Table 9 Control Systems

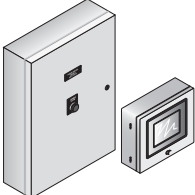
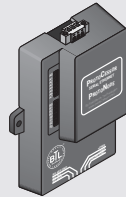
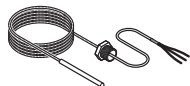
	Catalog number	Description
Electronic thermostats and accessories		
	ECW-GF	Electronic ambient sensing controller with 30-mA ground-fault protection. The controller can be programmed to maintain temperatures up to 200°F (93°C) at voltages from 100 to 277 V and can switch current up to 30 Amperes. The ECW-GF is complete with a 25-ft (7.6-m) temperature sensor and is housed in a Type 4X rated enclosure. The controller features an AC/DC dry alarm contact relay. An optional ground-fault display panel (ECW-GF-DP) can be added to provide ground-fault or alarm indication in applications where the controller is mounted in inaccessible locations.
	ECW-GF-DP	An optional remote display panel (ECW-GF-DP) can be added to provide ground-fault or alarm indication in applications where the controller is mounted in inaccessible locations.
	MI-GROUND-KIT	Grounding kit for nonmetallic enclosures (for MI only)
Electronic controllers and sensors		
	C910-485	The C910-485 is a compact, full featured, microprocessor-based, single-point commercial heating cable controller. The C910-485 provides control and monitoring of electrical heating cable circuits for commercial heating applications, with built-in ground-fault protection. The C910-485 can be set to monitor and alarm for high and low temperature, high and low current, ground-fault level, and voltage. Communications modules are available for remote control and configuration.
	ACS-UIT3 ACS-PCM2-5	The ACS-30 Advanced Commercial Control System is a multipoint electronic control and monitoring system for heat-tracing used in various commercial applications such as pipe freeze protection, roof and gutter de-icing, surface snow melting, hot water temperature maintenance and floor heating. The ACS-30 system can control up to 260 circuits with multiple networked ACS-PCM2-5 panels, with a single ACS-UIT3 user interface terminal. The ACS-PCM2-5 panel can directly control up to 5 individual heat-tracing circuits using electro-mechanical relays rated at 30 A up to 277 V.
	ProtoNode-RER-1.5K ProtoNode-RER-10K	ProtoNode is an external, high performance multi-protocol gateway for customers needing protocol translation between building management systems (BMS) using BACnet® or Metasys® N2 and the C910-485, ACS-30 controller. ProtoNode-RER-1.5K (Part No P000002008) is for C910-485 or ACS-30 systems with up to 5 PCM panels. ProtoNode-RER-10K (Part No P000001983) is for ACS-30 systems with up to 34 PCM panels.
	RTD-200 RTD10CS RTD50CS	Stainless steel jacketed three-wire RTD (Resistance Temperature Detector) used with C910-485 and ACS-30 controllers. RTD-200: 3-in (76 mm) temperature sensor with a 6-ft (1.8 m) lead wire and 1/2-in NPT bushing RTD10CS: temperature sensor with a 10-ft (3 m) flexible armor, 18-in (457 mm) lead wire and 1/2-inch NPT bushing RTD50CS: temperature sensor with a 50-ft (15.2 m) flexible armor, 18-in (457 mm) lead wire and 1/2-in NPT bushing

Example: RaySol and MI heating cables in conduit

Electronic thermostat	C910-485
Quantity	1

Freezer Frost Heave Prevention System Design Steps (in Conduit)	
1.	Determine the freezer configuration
2.	Select the heating cable
3.	Determine heating cable conduit spacing and freezer load
4.	Determine the heating cable layout and length
5.	Determine the electrical parameters
6.	Select the connection kits and accessories
7.	Select the control system
8.	Select the power distribution
9.	Complete the Bill of Materials

Step 8 Select the power distribution

For RaySol and MI Heating Cable in conduit

Power to the heating cables can be provided in several ways:

- Directly to the power connection kits (RaySol only)
- Directly through the temperature controller
- Through external contactors or through HTPG power distribution panels

Single circuit control

Heating cable circuits that do not exceed the current rating of the selected controller can be switched directly (Fig. 14). When the total electrical load exceeds the rating of the controller, an external contactor is required.

RaySol systems without temperature control can be connected directly to the power connection kits from the ground-fault circuit breakers in subpanels.

Group control

If the controller will activate multiple circuits (group control) then an external contactor must be used (Fig. 14).

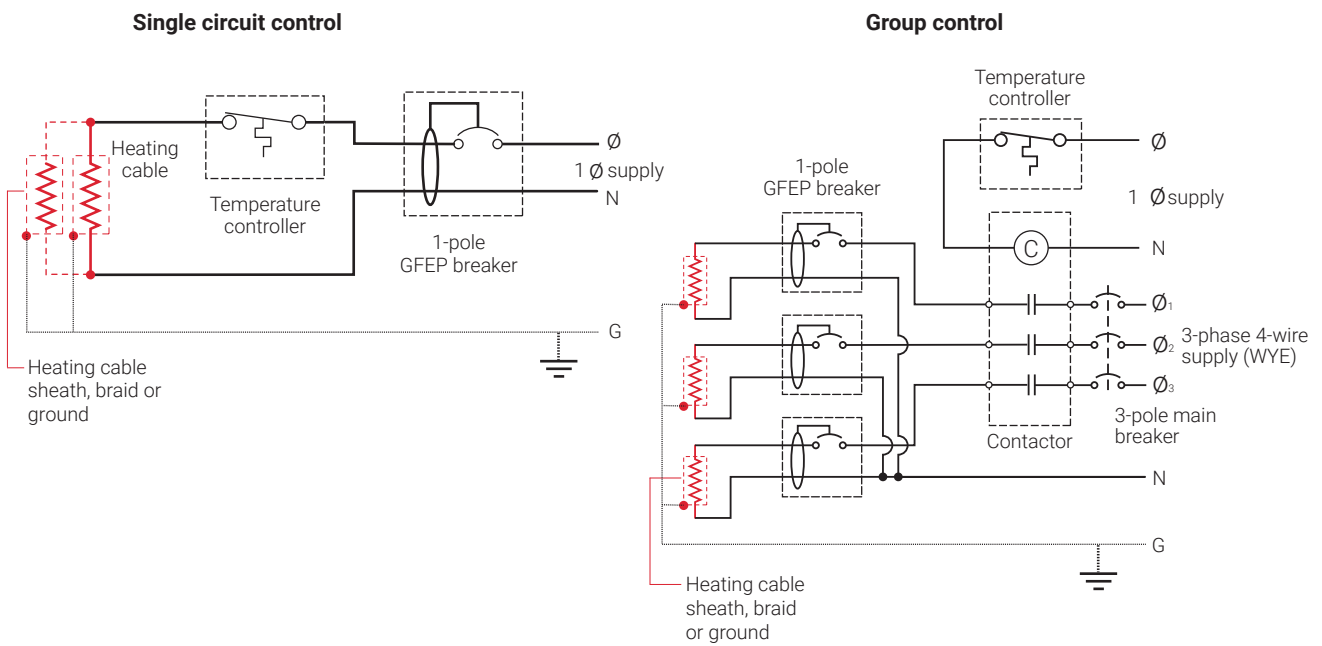

Fig. 14 Single circuit and group control

Large systems with many circuits should use an HTPG power distribution panel. The HTPG is a dedicated power-distribution, control, ground-fault protection, monitoring, and alarm panel for freeze protection and broad temperature-maintenance heat-tracing applications. This enclosure contains an assembled circuit-breaker panelboard. Panels are equipped with ground-fault circuit breakers with or without alarm contacts. The group control package allows the system to operate automatically in conjunction with a temperature control system.

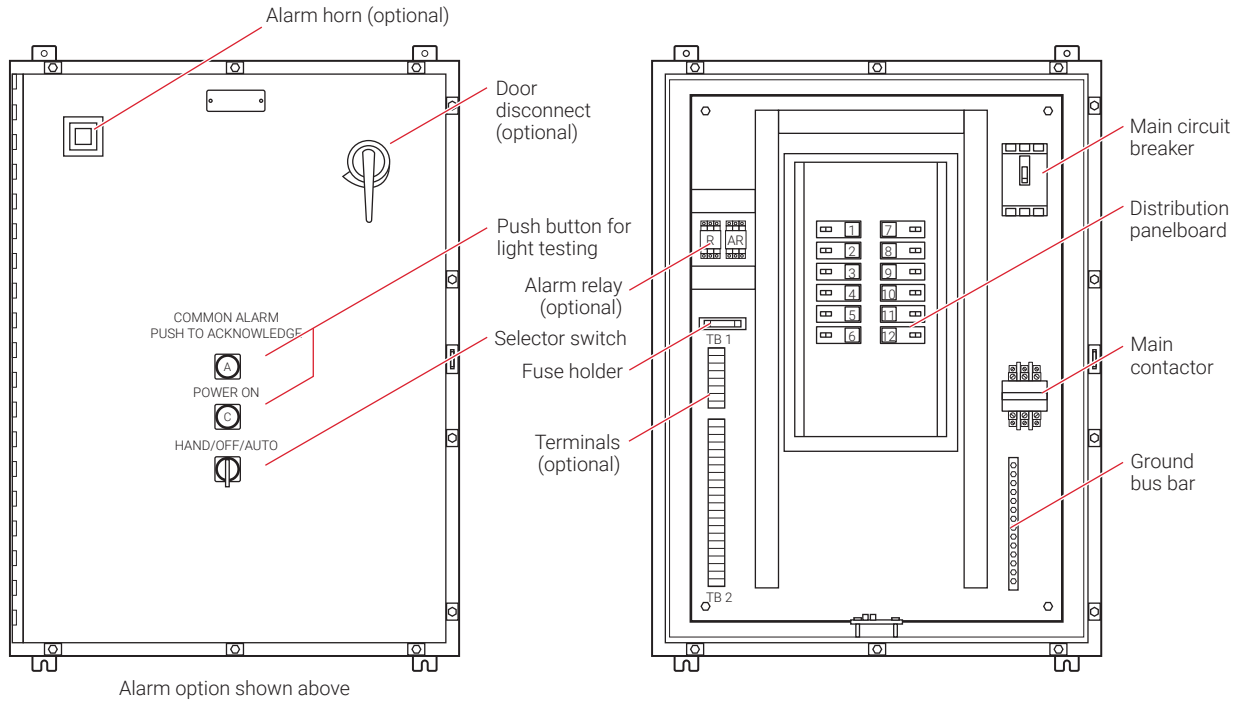

Fig. 15 HTPG power distribution panel

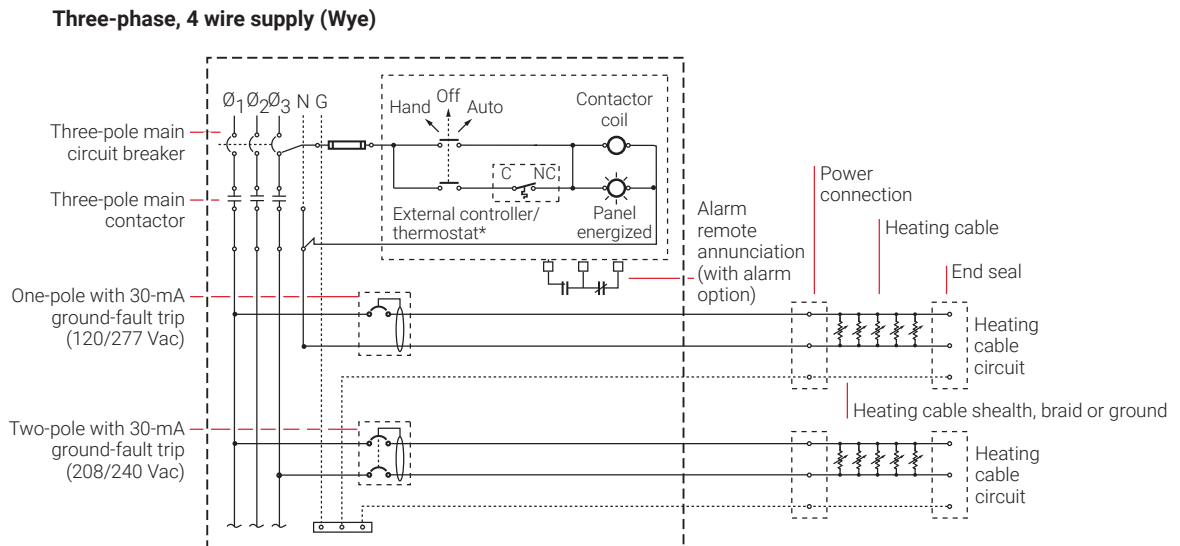
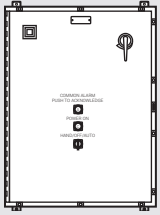

Fig. 16 HTPG power schematic

Table 10 Power Distribution

	Catalog number	Description
Power Distribution and Control Panels		
	HTPG	Heat-tracing power distribution panel with ground-fault and monitoring for group control.

Freezer Frost Heave Prevention System Design Steps (in Conduit)
1. Determine the freezer configuration
2. Select the heating cable
3. Determine heating cable conduit spacing and freezer load
4. Determine the heating cable layout and length
5. Determine the electrical parameters
6. Select the connection kits and accessories
7. Select the control system
8. Select the power distribution
9. Complete the Bill of Materials

Step 9 Complete the Bill of Materials

If you used the Design Worksheet to document all your design parameters, you should have all the details necessary complete your Bill of Materials.

Design Step by Step MI Heating Cables Directly Embedded

Embedding cables directly in sand (recommended), concrete, or compacted fill subfloors has the advantage of simpler installation and reduced costs. The number of electrical circuits can be minimized considerably compared to a similar installation using conduit. If embedded in a concrete subfloor below the insulation, the cable must not cross any joints in the subfloor.

Follow these steps to design your system:

- 1 Determine the freezer configuration
- 2 Determine heat loss and freezer load
- 3 Select the heating cable, layout and length
- 4 Determine the heating cable spacing
- 5 Determine the electrical parameters
- 6 Select the accessories
- 7 Select the control system
- 8 Select the power distribution
- 9 Complete the Bill of Materials

The "MI Cables Directly Embedded Freezer Frost Heave Prevention Design Worksheet" on page 54 is included to help you document the project parameters that you will need for your project's Bill of Materials.

Freezer Frost Heave Prevention System Design Steps (Embedded)	
1.	Determine the freezer configuration
2.	Determine heat loss and freezer load
3.	Select the heating cable, layout and length
4.	Determine the heating cable spacing
5.	Determine the electrical parameters
6.	Select the accessories
7.	Select the control system
8.	Select the power distribution
9.	Complete the Bill of Materials

Step 1 Determine the freezer configuration

Gathering Information

The following information is required to complete the freezer frost heave prevention system design.

- Size and layout of freezer or ice arena
- Freezer operating temperature
- Insulation R-value
- Supply voltage and phase
- Control requirements

Prepare scale drawing

Draw to scale the floor area to be heated. Carefully note the limits of the area to be heated. Show all concrete joints on the drawing and note the location and size of obstacles, such as floor drains, pipe penetrations, columns, fixtures, and voltage supply location.

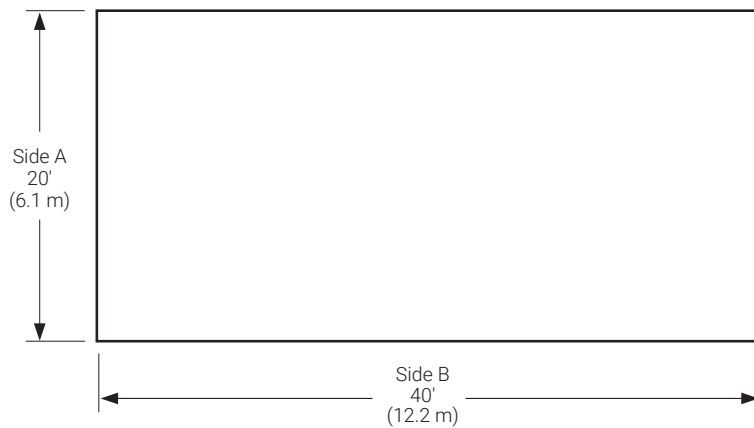

Fig. 17 Typical freezer example - single-phase

Determine freezer operating temperature

Determine the temperature at which your freezer operates. If it operates at more than one temperature, or if the operating temperature may be changed in the future, base the design on the lowest anticipated operating temperature.

Record insulation R-value

The insulation R-value is the thermal resistance of the floor's insulation. Normally the R-value will be printed on the insulation material. If that is not the case, you can calculate it by dividing the insulation thickness in inches by the insulation thermal conductivity.

Example: MI heating cables directly embedded – Single-phase

Area	40 ft x 20 ft = 800 ft ² (12.2 m x 6.1 m = 74 m ²)
Freezer operating temperature	-30°F (-34°C)
Insulation R-value	R-20 (20 ft ² ·°F·hr/Btu)
Supply voltage	208 V, single-phase

Example: MI heating cables directly embedded – Three-phase

Area	80 ft x 80 ft = 6400 ft ² (24.4 m x 24.4 m = 595 m ²)
Freezer operating temperature	-20°F (-29°C)
Insulation R-value	R-20 (20 ft ² ·°F·hr/Btu)
Supply voltage	208 V, three-phase

Freezer Frost Heave Prevention System Design Steps (Embedded)
1. Determine the freezer configuration
2. Determine heat loss and freezer load
3. Select the heating cable, layout and length
4. Determine the heating cable spacing
5. Determine the electrical parameters
6. Select the accessories
7. Select the control system
8. Select the power distribution
9. Complete the Bill of Materials

Step 2 Determine heat loss and freezer load

In Table 11, we have calculated the heat loss for directly embedded MI heating cable systems based on the freezer temperatures and the floor insulation R-values; from this table, you will select your design power and freezer load.

If your calculated R-value or freezer operating temperature does not match the values in the table, use the values that give the higher design power.

Within each cell, there are two numbers; design power and freezer load. Freezer load is the additional cooling load imposed on the cooling system by the freezer frost heave prevention heating cable. It is the heat transferred through the insulation into the freezer, expressed in W/ft² (W/m²) of floor area.

Table 11 MI Heating Cable: Design Power Requirement and Freezer Load based on 40°F (5°C) Control

Freezer operating temperature				Floor insulation R-value (ft ² ·°F·hr/Btu)							
				R-10		R-20		R-30		R-40	
30°F (-1°C)	Design power	W/ft ² (W/m ²)	0.5 (5.4)	0.2 (2.2)	0.1 (1.1)	0.1 (1.1)	0.1 (1.1)	0.1 (1.1)	0.1 (1.1)		
	Freezer load	W/ft ² (W/m ²)	0.7 (7.5)	0.4 (4.3)	0.3 (3.2)	0.3 (3.2)	0.3 (3.2)	0.3 (3.2)	0.3 (3.2)		
20°F (-7°C)	Design power	W/ft ² (W/m ²)	0.6 (6.5)	0.4 (4.3)	0.2 (2.2)	0.2 (2.2)	0.1 (1.1)	0.1 (1.1)	0.1 (1.1)		
	Freezer load	W/ft ² (W/m ²)	0.8 (8.6)	0.5 (5.4)	0.4 (4.3)	0.4 (4.3)	0.3 (3.2)	0.3 (3.2)	0.3 (3.2)		
10°F (-12°C)	Design power	W/ft ² (W/m ²)	0.9 (9.7)	0.6 (6.5)	0.3 (3.2)	0.3 (3.2)	0.2 (2.2)	0.2 (2.2)	0.2 (2.2)		
	Freezer load	W/ft ² (W/m ²)	1.0 (10.8)	0.6 (6.5)	0.4 (4.3)	0.4 (4.3)	0.3 (3.2)	0.3 (3.2)	0.3 (3.2)		
0°F (-18°C)	Design power	W/ft ² (W/m ²)	1.1 (11.8)	0.7 (7.5)	0.5 (5.4)	0.5 (5.4)	0.3 (3.2)	0.3 (3.2)	0.3 (3.2)		
	Freezer load	W/ft ² (W/m ²)	1.3 (14.0)	0.8 (8.6)	0.5 (5.4)	0.5 (5.4)	0.4 (4.3)	0.4 (4.3)	0.4 (4.3)		
-10°F (-23°C)	Design power	W/ft ² (W/m ²)	1.4 (15.1)	0.8 (8.6)	0.6 (6.5)	0.6 (6.5)	0.4 (4.3)	0.4 (4.3)	0.4 (4.3)		
	Freezer load	W/ft ² (W/m ²)	1.5 (16.1)	0.8 (8.6)	0.6 (6.5)	0.6 (6.5)	0.5 (5.4)	0.5 (5.4)	0.5 (5.4)		
-20°F (-29°C)	Design power	W/ft ² (W/m ²)	1.6 (17.2)	0.9 (9.7)	0.7 (7.5)	0.7 (7.5)	0.5 (5.4)	0.5 (5.4)	0.5 (5.4)		
	Freezer load	W/ft ² (W/m ²)	1.8 (19.4)	1.0 (10.8)	0.7 (7.5)	0.7 (7.5)	0.6 (6.5)	0.6 (6.5)	0.6 (6.5)		
-30°F (-34°C)	Design power	W/ft ² (W/m ²)	1.7 (18.3)	1.1 (11.8)	0.8 (8.6)	0.8 (8.6)	0.6 (6.5)	0.6 (6.5)	0.6 (6.5)		
	Freezer load	W/ft ² (W/m ²)	2.0 (21.5)	1.1 (11.8)	0.8 (8.6)	0.8 (8.6)	0.6 (6.5)	0.6 (6.5)	0.6 (6.5)		
-40°F (-40°C)	Design power	W/ft ² (W/m ²)	2.0 (21.5)	1.2 (12.9)	0.8 (8.6)	0.8 (8.6)	0.7 (7.5)	0.7 (7.5)	0.7 (7.5)		
	Freezer load	W/ft ² (W/m ²)	2.3 (24.7)	1.2 (12.9)	0.8 (8.6)	0.8 (8.6)	0.7 (7.5)	0.7 (7.5)	0.7 (7.5)		

Example: MI heating cables directly embedded – Single-phase

Freezer operating temperature -30°F (-34°C) (from Step 1)
 Insulation R-value R-20 (20 ft²·°F·hr/Btu) (from Step 1)
 Design power **1.1 W/ft² (11.8 W/m²)**
 Freezer load **1.1 W/ft² (11.8 W/m²)**

Example: MI heating cables directly embedded – Three-phase

Freezer operating temperature -20°F (-29°C) (from Step 1)
 Insulation R-value R-20 (20 ft²·°F·hr/Btu) (from Step 1)
 Design power **0.9 W/ft² (9.7 W/m²)**
 Freezer load **1.0 W/ft² (10.8 W/m²)**

Freezer Frost Heave Prevention System Design Steps (Embedded)
1. Determine the freezer configuration
2. Determine heat loss and freezer load
3. Select the heating cable, layout and length
4. Determine the heating cable spacing
5. Determine the electrical parameters
6. Select the accessories
7. Select the control system
8. Select the power distribution
9. Complete the Bill of Materials

Step 3 Select the heating cable, layout and length

To select the correct MI heating cable for the heated area, you must determine the wattage required for the area or subsection area.

For small freezers, one heating cable may be sufficient. For large freezers, it may be necessary to divide the freezer into two or more equal subsection areas. To balance the load in a three-phase circuit, three cables will be required, or a multiple of three cables when more than one three-phase circuit is required. If the heating cables are to be embedded in a concrete subfloor, divide the area so that the heating cables will not cross any joints in the subfloor.

The heating cables shown in Table 12 are general purpose cables and may be used for a variety of applications depending on the supply voltage; the heating cables in Table 13 have been optimized for frost heave prevention applications. If assistance is required to select heating cables for irregular shaped areas or applications outside the scope of this design guide, contact your Chemelex representative for assistance in designing a custom heating cable.

Single-phase supply

Small freezer areas require only one heating cable. Large freezer areas may require two or more heating cables.

- Divide large freezer areas into equal subsection areas, if possible.
- Calculate the power required for the total area (small freezers) or for each subsection area (large freezers) by multiplying the design power (from Table 11) by the total area or subsection area.

Power required = Design power x Total area (or Subsection area)

Simply select the heating cable from Table 12 or Table 13 based on the total area or subsection area. Under the appropriate voltage, make sure that the total area or subsection area falls within the minimum and maximum range of the "Area coverage" columns and verify that the "Cable wattage" shown directly across from the "Area coverage" is equal to or higher than the calculated "Power required" for the total area or subsection area (see example following).

 **Note:** If two or more cables in the Tables meet the requirements, use the cable with the lower wattage.

In cases where the freezer area has been divided into equal subsections, select the appropriate number of heating cables. Where heating cables are directly embedded in concrete subfloors, calculate the wattage required for each area bounded by joints in the subfloor and select an appropriate cable for each area.

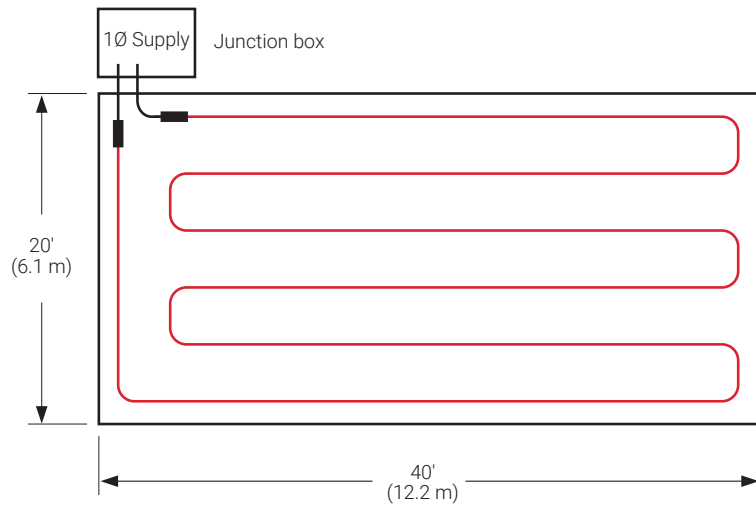

Fig. 18 Single-phase layout

Example: MI heating cables directly embedded – Single-phase

Area	800 ft ² (74 m ²) (See Fig. 18)
Design power	1.1 W/ft ² (11.8 W/m ²) (from Step 2)
Power required	Design power x Area = 1.1 W/ft ² x 800 ft ² = 880 W (11.8 W/m ² x 74 m ² = 880 W)
Supply voltage	208 V, single-phase (from Step 1)
Catalog number	SUB19
Cable wattage	885 W
Heated length	245 ft (74.7 m)
Quantity	1

Three-phase supply

Designing the frost heave prevention system using a three-phase voltage supply has the added advantages of fewer circuits, reduced distribution costs, and a balanced heating system load and is recommended for large freezers.

Three-phase voltages include 208/120 V, 480/277 V, and 600/347 V. When selecting heating cables for three-phase voltages, cable layout will be easier if the heating cables are wye connected (Fig. 19); therefore select the cables based on the phase-to-neutral voltage (e.g., select 277 V cables for a 480 V supply).

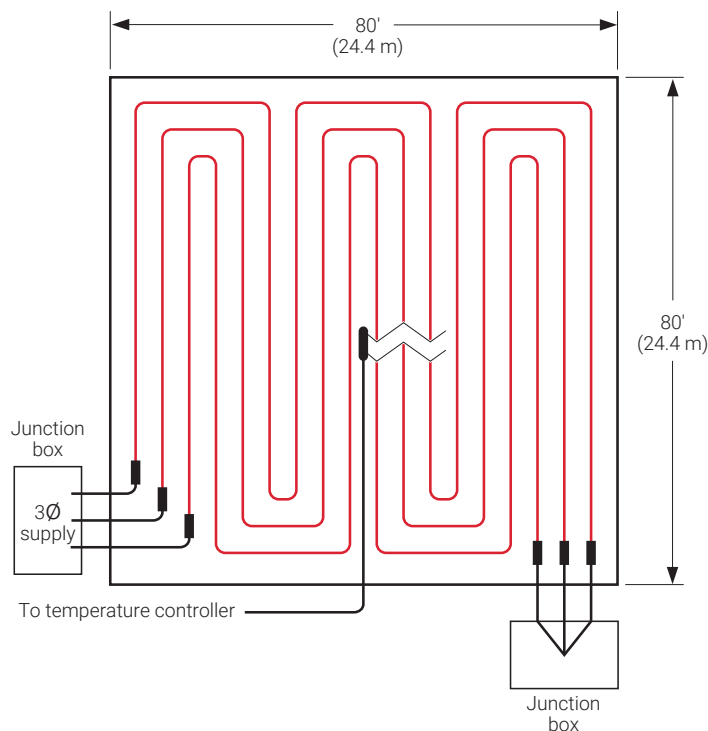

Fig. 19 Three-phase wye connected heating cable layout

Since a balanced three-phase system requires three cables, each cable will occupy 1/3 of the freezer area when installed.

- Calculate the "Power required" by multiplying the design power from Table 11 by the total freezer area.
- Divide the total freezer area by three to determine the "Area coverage for each cable."
- Calculate the "Wattage for each cable" by dividing the "Power required" by three.

$$\text{Wattage for each cable} = (\text{Design power} \times \text{Total freezer area}) / 3$$

Simply select the heating cable from Table 12 on page 38 or Table 13 on page 39 based on the area coverage for each cable. Under the appropriate voltage, make sure that the area coverage for each cable falls within the minimum and maximum range of the "Area coverage" columns and verify that the "Cable wattage" shown directly across from the "Area coverage" is equal to or higher than the calculated "Wattage for each cable" (see example following). Three of the same cables are required for balanced three-phase systems.

Note: If two or more cables in the Tables meet the requirements, use the cable with the lower wattage.

Note: For very large freezers, it may be necessary to divide the freezer into subsections and use two or more three-phase circuits.

Example: MI heating cables directly embedded – Three-phase

Area	6400 ft ² (595 m ²) (see Fig. 19)
Design power	0.9 W/ft ² (9.7 W/m ²) (from Step 2)
Power required	(Design Power x Area) = (0.9 W/ft ² x 6400 ft ²) = 5760 W (9.7 W/m ² x 595 m ²) = 5760 W
Area coverage for each cable	Area/3 = 6400 ft ² /3 = 2133 ft ² (595 m ² /3 = 198.3 m ²)
Wattage for each cable	Power required/3 = 5760/3 = 1920 W
Supply voltage connection)	208 V, three-phase (from Step 1) (select 120 volt cable for wye
Catalog number	SUB8
Cable wattage	2300 W
Cable voltage	120 V
Heated length	550 ft (167.6 m)
Quantity	3

Table 12 Selection Table for MI Heating Cables for Directly Embedded Cables

Catalog number	Area coverage				Cable wattage (W)	Heated length ¹		Heating cable current (A) ²
	Min (ft ²)	Max (ft ²)	Min (m ²)	Max (m ²)		(ft)	(m)	
120 V and 208 V, three-phase wye								
SUA3	205	700	19.1	65.1	500	140	42.7	4.2
SUA4	220	340	20.4	31.6	550	68	20.7	4.6
SUA7	300	480	27.9	44.6	750	95	29.0	6.3
SUA8	310	885	28.8	82.2	800	177	53.9	6.7
SUB1	420	660	39.0	61.3	1000	132	40.2	8.3
SUB2	400	1200	37.2	111.5	1000	240	73.1	8.3
SUB3	520	1400	48.3	130.1	1300	280	85.3	10.8
SUB4	600	1600	55.8	148.7	1500	320	97.5	12.5
SUB5	750	1300	69.7	120.8	1800	260	79.2	15.0
SUB6	780	1875	72.5	174.3	1900	375	114.3	15.8
SUB7	940	1550	87.4	144.1	2300	310	94.5	19.2
SUB8	930	2750	86.4	255.6	2300	550	167.6	19.2
SUB9	1250	3150	116.2	292.8	3000	630	192.0	25.0
SUB10	1700	3585	158.0	333.2	4300	717	218.5	35.8
208 V								
SUA1	260	540	24.2	50.2	650	108	32.9	3.1
SUA6	650	1320	60.4	122.7	1560	264	80.5	7.5
SUB19	350	1225	32.5	113.8	885	245	74.7	4.3
SUB20	480	1700	44.6	158.0	1210	340	103.6	5.8
SUB21	650	2200	60.4	204.5	1640	440	134.1	7.9
SUB22	820	2625	76.2	244.0	2060	525	160.0	9.9
240 V								
SUB19	350	1225	32.5	113.8	1175	245	74.7	4.9
SUB20	480	1700	44.6	158.0	1615	340	103.6	6.7
SUB21	650	2200	60.4	204.5	2180	440	134.1	9.1
SUB22	820	2625	76.2	244.0	2745	525	160.0	11.4
277 V and 480 V, three-phase wye								
SUB19	400	1225	37.2	113.8	1565	245	74.7	5.6
SUB20	550	1700	51.1	158.0	2150	340	103.6	7.8
SUB21	720	2200	66.9	204.5	2900	440	134.1	10.5
SUB22	940	2625	87.4	244.0	3650	525	160.0	13.2
347 V and 600 V, three-phase wye								
SUB11	540	1125	50.2	104.6	1400	225	68.6	4.0
SUB12	770	1550	71.6	144.1	1950	310	94.5	5.6
SUB13	1060	2140	98.5	198.9	2700	428	130.5	7.8
SUB14	1440	2740	133.8	254.6	3700	548	167.0	10.7

¹ Tolerance on heating cable length is -0% to +3%

² Single-phase current shown

Note: Type SUA cables supplied with 7 ft (2.1 m) long cold lead; type SUB cables supplied with 15 ft (4.6 m) long cold leads.

Table 13 Selection Table for MI Heating Cables for Directly Embedded Cables

Catalog number	Area coverage				Cable wattage (W)	Heated length ¹		Heating cable current (A) ²
	Min (ft ²)	Max (ft ²)	Min (m ²)	Max (m ²)		(ft)	(m)	
120 V and 208 V, three-phase Wye								
FFHP1	163	290	15.1	27.0	405	58	17.7	3.4
FFHP2	205	360	19.1	33.5	510	72	22.0	4.3
FFHP3	231	415	21.5	38.6	580	83	25.3	4.8
FFHP4	282	510	26.2	47.4	705	102	31.1	5.9
FFHP5	328	585	30.5	54.4	820	117	35.7	6.8
FFHP6	392	700	36.4	65.1	980	140	42.7	8.2
FFHP7	450	800	41.8	74.3	1125	160	48.8	9.4
FFHP8	519	925	48.2	86.0	1300	185	56.4	10.8
FFHP9	637	1130	59.2	105.0	1590	226	68.9	13.3
FFHP10	733	1310	68.1	121.7	1830	262	79.9	15.3
FFHP11	900	1600	83.6	148.7	2250	320	97.6	18.8
FFHP12	1186	2130	110.2	198.0	2965	426	129.9	24.7
FFHP13	1470	2640	136.6	245.4	3675	528	161.0	30.6
FFHP14	1862	3320	173.0	308.6	4650	664	202.4	38.8
208 V								
FFHP15	281	505	26.1	46.9	700	101	30.8	3.4
FFHP16	352	630	32.7	58.6	880	126	38.4	4.2
FFHP17	401	720	37.2	66.9	1000	144	43.9	4.8
FFHP18	492	880	45.7	81.8	1230	176	53.7	5.9
FFHP19	568	1015	52.8	94.3	1420	203	61.9	6.8
FFHP20	678	1215	63.0	112.9	1700	243	74.1	8.2
FFHP21	778	1390	72.3	129.2	1945	278	84.8	9.4
FFHP22	901	1600	83.8	148.7	2250	320	97.6	10.8
FFHP23	1098	1970	102.1	183.1	2745	394	120.1	13.2
FFHP24	1268	2275	117.8	211.4	3170	455	138.7	15.2
FFHP25	1553	2785	144.4	258.8	3885	557	169.8	18.7
240 V								
FFHP26	326	580	30.3	53.9	815	116	35.4	3.4
FFHP27	407	725	37.9	67.4	1020	145	44.2	4.3
FFHP28	463	830	43.0	77.1	1160	166	50.6	4.8
FFHP29	567	1015	52.7	94.3	1420	203	61.9	5.9
FFHP30	656	1170	61.0	108.7	1640	234	71.3	6.8
FFHP31	786	1395	73.1	129.6	1965	279	85.1	8.2
FFHP32	900	1600	83.6	148.7	2250	320	97.6	9.4
FFHP33	1038	1850	96.5	171.9	2600	370	112.8	10.8
FFHP34	1274	2260	118.4	210.0	3185	452	137.8	13.3
FFHP35	1471	2610	136.7	242.6	3680	522	159.1	15.3
FFHP36	1800	3200	167.3	297.4	4500	640	195.1	18.8

¹ Tolerance on heating cable length is -0% to +3%.

² Single-phase current shown

Note: Type FFHP cables supplied with 15 ft (4.6 m) long cold leads.

Catalog number	Area coverage				Cable wattage (W)	Heated length ¹		Heating cable current (A) ²
	Min (ft ²)	Max (ft ²)	Min (m ²)	Max (m ²)		(ft)	(m)	
277 V and 480 V, three-phase wye								
FFHP37	375	670	34.9	62.3	940	134	40.9	3.4
FFHP38	468	840	43.5	78.1	1170	168	51.2	4.2
FFHP39	536	955	49.8	88.8	1340	191	58.2	4.8
FFHP40	656	1170	60.9	108.7	1640	234	71.3	5.9
FFHP41	758	1350	70.4	125.5	1895	270	82.3	6.8
FFHP42	908	1610	84.4	149.6	2270	322	98.2	8.2
FFHP43	1037	1850	96.4	171.9	2590	370	112.8	9.4
FFHP44	1201	2130	111.6	198.0	3000	426	129.9	10.8
FFHP45	1462	2625	135.8	244.0	3655	525	160.1	13.2
FFHP46	1697	3015	157.7	280.2	4240	603	183.8	15.3
FFHP47	2074	3700	192.7	343.9	5185	740	225.6	18.7
347 V and 600 V, three-phase wye								
FFHP48	470	840	43.7	78.1	1175	168	51.2	3.4
FFHP49	588	1050	54.7	97.6	1470	210	64.0	4.2
FFHP50	672	1195	62.4	111.1	1680	239	72.9	4.8
FFHP51	819	1470	76.1	136.6	2050	294	89.6	5.9
FFHP52	950	1690	88.3	157.1	2375	338	103.0	6.8
FFHP53	1133	2025	105.3	188.2	2830	405	123.5	8.2
FFHP54	1295	2325	120.3	216.1	3240	465	141.8	9.3
FFHP55	1500	2675	139.4	248.6	3750	535	163.1	10.8
FFHP56	1838	3275	170.8	304.4	4600	655	199.7	13.3
FFHP57	2126	3775	197.6	350.8	5315	755	230.2	15.3

¹ Tolerance on heating cable length is -0% to +3%.

² Single-phase current shown

Note: Type FFHP cables supplied with 15 ft (4.6 m) long cold leads.

Freezer Frost Heave Prevention System Design Steps (Embedded)
1. Determine the freezer configuration
2. Determine heat loss and freezer load
3. Select the heating cable, layout and length
4. Determine the heating cable spacing
5. Determine the electrical parameters
6. Select the accessories
7. Select the control system
8. Select the power distribution
9. Complete the Bill of Materials

Step 4 Determine the heating cable spacing

To determine the spacing between runs of heating cables, use the formula below:

$$\text{Cable spacing (in)} = \frac{\text{Area (ft}^2\text{)} \times 12 \text{ in}}{\text{Heated length (ft)}}$$

$$\text{Cable spacing (cm)} = \frac{\text{Area (m}^2\text{)} \times 100 \text{ cm}}{\text{Heated length (m)}}$$

 **Note:** If a large area has been divided into subsections or if a three-phase voltage supply is used, the “Area” in the above equations will be the subsection area or area coverage for each cable and the “Heated length” will be the length of the selected cable.

Example: MI heating cables directly embedded – Single-phase

Area	800 ft ² (74 m ²) (from Step 3)
Catalog number	SUB19 (from Step 3)
Heated length	245 ft (74.7 m) (from Step 3)
Cable spacing	800 ft² x 12 / 245 ft = 39.2 in rounded to 39 in
	74 m² x 100 / 74.7 m = 99.1 cm rounded to 99 cm

Example: MI heating cables directly embedded – Three-phase

Area coverage for each cable	2133 ft ² (198.3 m ²) (from Step 3)
Catalog number	SUB8 (from Step 3)
Heated length	550 ft (167.6 m) (from Step 3)
Cable spacing	2133 ft² x 12 / 550 ft = 46.5 in rounded to 47 in
	198.3 m² x 100 / 167.6 m = 118.3 cm rounded to 118 cm

Freezer Frost Heave Prevention System Design Steps (Embedded)
1. Determine the freezer configuration
2. Determine heat loss and freezer load
3. Select the heating cable, layout and length
4. Determine the heating cable spacing
5. Determine the electrical parameters
6. Select the accessories
7. Select the control system
8. Select the power distribution
9. Complete the Bill of Materials

Step 5 Determine the electrical parameters

Determine number of circuits

For single-phase circuits, when connecting individual heating cables to circuit breakers, the cable current draw must not exceed 80% of the circuit breaker rating. To reduce the number of circuits, multiple heating cables may be connected in parallel. When multiple cables are connected in parallel, the total of the individual heating cable currents must not exceed 80% of the circuit breaker rating. The single-phase heating cable current is shown in Table 12 and Table 13.

For three-phase circuits used in frost heave protection systems, the three heating cables are generally connected in the wye configuration shown in Fig. 21 on page 46. For a wye connected three-phase circuit, the current draw is the same as the single-phase heating cable current and must not exceed 80% of the 3-pole circuit breaker rating.

A 30-mA ground-fault protection device (GFPD) must be used to provide protection from arcing or fire, and to comply with warranty requirements, agency certifications, and national electrical codes. If the heating cable is improperly installed, or physically damaged, sustained arcing or fire could result. If arcing does occur, the fault current may be too low to trip conventional circuit breakers.

⚠ WARNING: To minimize the danger of fire from sustained electrical arcing if the heating cable is damaged or improperly installed, and to comply with the requirements of Chemelex, agency certifications, and national electrical codes, ground-fault equipment protection must be used on each heating cable branch circuit. Arcing may not be stopped by conventional circuit protection.

Select branch circuit breaker size

Record the number and ratings of the circuit breakers to be used. Use ground-fault protection devices (GFPDs) for all applications. For three-phase circuits, ground fault may be accomplished using a shunt trip 3-pole breaker and a ground fault sensor.

Determine transformer load

The total transformer load is the sum of the wattages of the selected heating cables.

Calculate the Total Transformer Load as follows:

$$\text{Transformer load (kW)} = \frac{\text{Cable}_1 \text{ (W)} + \text{Cable}_2 \text{ (W)} + \text{Cable}_3 \text{ (W)} \dots + \text{Cable}_N \text{ (W)}}{1000}$$

Example: MI heating cables directly embedded – Single-phase

Amps	4.3 A (from Table 12)
Circuit breaker size	15 A breaker, 80% loading 12 A
Number of circuit breakers	1
Cable power output	885 W (from Step 3)
Number of cables	1 (from Step 3)
Transformer load	885 W / 1000 = 0.9 kW

Example: MI heating cables directly embedded – Three-phase

Amps/cable	19.2 A (from Table 12)
Circuit breaker size	25 A, 3-pole breaker, 80% loading 20 A
Number of circuit breakers	1 (3 cables wye connected – see Fig. 21)
Cable power output	2300 W (from Step 3)
Number of cables	3 (from Step 3)
Total Transformer load	(2300 W x 3) / 1000 = 6.9 kW

Record the number and ratings of the circuit breakers to be used and total transformer load on the worksheet.

Freezer Frost Heave Prevention System Design Steps (Embedded)
1. Determine the freezer configuration
2. Determine heat loss and freezer load
3. Select the heating cable, layout and length
4. Determine the heating cable spacing
5. Determine the electrical parameters
6. Select the accessories
7. Select the control system
8. Select the power distribution
9. Complete the Bill of Materials

Step 6 Select the accessories

For your embedded system, determine the number of junction boxes required.

Select Junction Box

Select a UL Listed and/or CSA Certified junction box that is suitable for the location, such as the MIJB-864-A. Use a box with minimum internal volume of 16 cubic inches if the box is metallic and 19 cubic inches if the box is not metallic. Metal junction boxes are recommended.

 **Note:** The junction box must be accessible according to the national electrical codes.

After determining the number of heating cables required, the number of circuits, and the junction box locations, do a trial layout. In making the trial layout, follow these recommendations:

- Install the heating cables in a sand layer beneath the insulation.
- Maintain the design spacing within 4 in (10 cm).
- When directly embedded in the concrete floor, do not cross expansion joints in the floor.
- Do not route the cables closer than 4 in (10 cm) to the edge of the subfloor, drains, anchors, or other material.

Table 14 Accessories

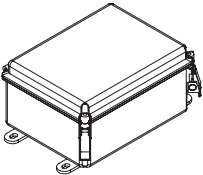
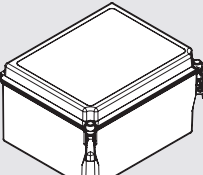
	Catalog number	Description	Standard packaging	Usage
	MIJB-864-A	Junction box with pre-drilled earth plate for use with MI heating units. Typical uses - Power, splice and end box for three-phase systems. Hazardous locations: CID2 Groups B, C and D. Maximum operating voltage 600Vac. Maximum 35A per terminal, rated 18AWG to 6AWG, Type 4X. Entries: Up to 8 x ½" and 3 x ¾". Power cable gland and hubs not included. Two mounting brackets (MBRP-B) and two pipe straps must be ordered separately for installation. Enclosure dimensions: 8" x 6" x 4" (200 x 150 x 100 mm).	1	For MI systems only
	MIJB-1086-B	Junction box with pre-drilled earth plate for use with MI heating units. Accommodates up to 7 outgoing heating cables and one incoming power cable. It can also be used as a marshalling box - one incoming power cable and 5 outgoing power cables. Typical uses - Power or marshalling, splice and end box for three-phase systems. Hazardous locations: CID2 Groups B, C and D. Maximum operating voltage 600Vac. Maximum 35A per terminal, rated 18AWG to 6AWG, Type 4X. Entries: Up to 11 x ½" and 8 x ¾". Power cable gland and hubs not included. Two mounting brackets (MBRP-B) and two pipe straps must be ordered separately for installation. Order a separate MIJB-LPWR-KIT for #2 or #4AWG power cable to downsize to #6AWG (35A). Enclosure dimensions: 10" x 8" x 6" (250 x 200 x 150 mm).	1	For MI systems only

Example: MI heating cables directly embedded - Single-phase

Junction box MIJB-864-A
Quantity required 1

Example: MI heating cables directly embedded - Three-phase

Junction box MIJB-1086-B
Quantity required 2

Freezer Frost Heave Prevention System Design Steps (Embedded)
1. Determine the freezer configuration
2. Determine heat loss and freezer load
3. Select the heating cable, layout and length
4. Determine the heating cable spacing
5. Determine the electrical parameters
6. Select the accessories
7. Select the control system
8. Select the power distribution
9. Complete the Bill of Materials

Step 7 Select the control system

For MI cable, a temperature controller must be used to maintain the subfloor temperature at 40°F (4°C). For installations where temperature control and temperature monitoring is desired, a C910-485 or ACS-30 controller is recommended. For additional information on temperature controller options, refer to Table 8 on page 25.

Table 15 Control Systems



	Catalog number	Description
Electronic thermostats and accessories		
	ECW-GF	Electronic ambient sensing controller with 30-mA ground-fault protection. The controller can be programmed to maintain temperatures up to 200°F (93°C) at voltages from 100 to 277 V and can switch current up to 30 Amperes. The ECW-GF is complete with a 25-ft (7.6-m) temperature sensor and is housed in a Type 4X rated enclosure. The controller features an AC/DC dry alarm contact relay. An optional ground-fault display panel (ECW-GF-DP) can be added to provide ground-fault or alarm indication in applications where the controller is mounted in inaccessible locations.
	ECW-GF-DP	An optional remote display panel (ECW-GF-DP) that can be added to provide ground-fault or alarm indication in applications where the controller is mounted in inaccessible locations.
	MI-GROUND-KIT	Grounding kit for nonmetallic enclosures (for MI only)
Electronic controllers and sensors		
	C910-485	The C910-485 is a compact, full featured, microprocessor-based, single-point commercial heating cable controller. The C910-485 provides control and monitoring of electrical heating cable circuits for commercial heating applications, with built-in ground-fault protection. The C910-485 can be set to monitor and alarm for high and low temperature, high and low current, ground-fault level, and voltage. Communications modules are available for remote control and configuration.

Table 15 Control Systems

	Catalog number	Description
	ACS-UIT3 ACS-PCM2-5	The ACS-30 Advanced Commercial Control System is a multipoint electronic control and monitoring system for heat-tracing used in various commercial applications such as pipe freeze protection, roof and gutter de-icing, surface snow melting, hot water temperature maintenance and floor heating. The ACS-30 system can control up to 260 circuits with multiple networked ACS-PCM2-5 panels, with a single ACS-UIT3 user interface terminal. The ACS-PCM2-5 panel can directly control up to 5 individual heat-tracing circuits using electromechanical relays rated at 30 A up to 277 V.
	ProtoNode-RER-1.5K ProtoNode-RER-10K	ProtoNode is an external, high performance multi-protocol gateway for customers needing protocol translation between building management systems (BMS) using BACnet® or Metasys® N2 and the C910-485, ACS-30 controller. ProtoNode-RER-1.5K (Part No P000002008) is for C910-485 or ACS-30 systems with up to 5 PCM panels. ProtoNode-RER-10K (Part No P000001983) is for ACS-30 systems with up to 34 PCM panels.
	RTD-200 RTD10CS RTD50CS	Stainless steel jacketed three-wire RTD (Resistance Temperature Detector) used with C910-485 and ACS-30 controllers. RTD-200: 3-in (76 mm) temperature sensor with a 6-ft (1.8 m) lead wire and 1/2-in NPT bushing RTD10CS: temperature sensor with a 10-ft (3 m) flexible armor, 18-in (457 mm) lead wire and 1/2-inch NPT bushing RTD50CS: temperature sensor with a 50-ft (15.2 m) flexible armor, 18-in (457 mm) lead wire and 1/2-in NPT bushing

Example: MI heating cables directly embedded - Single-phase

Single circuit, electronic controller **C910-485**
Quantity **1**

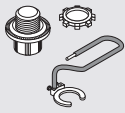
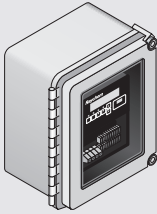
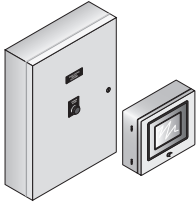
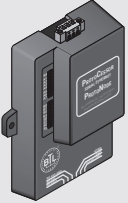
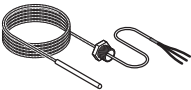
Example: MI heating cables directly embedded - Three-phase

Single circuit, monitoring requested **ACS-30***
Quantity **1**

*Use ACS-30 General part number (P000001232) for custom three-phase panels. Please contact your Chemelex representative for a custom ACS-PCM2-5 panel quotation.

Freezer Frost Heave Prevention System Design Steps (Embedded)
1. Determine the freezer configuration
2. Determine heat loss and freezer load
3. Select the heating cable, layout and length
4. Determine the heating cable spacing
5. Determine the electrical parameters
6. Select the accessories
7. Select the control system
8. Select the power distribution
9. Complete the Bill of Materials

Step 8 Select the power distribution

Power to the heating cables can be provided in three ways:

1. Directly through the temperature controller
2. Through external contactors activated by a temperature controller
3. Through an HTPG power distribution panel

Single circuit control

Heating cable circuits that do not exceed the current rating of the selected controller can be switched directly (Fig. 20). When the total electrical load exceeds the rating of the controller or if a single-pole temperature controller is used to control a three-phase circuit (Fig. 21), an external contactor is required.

Group control

If the temperature controller will activate multiple single-phase or three-phase circuits (group control), then an external contactor must be used. In Fig. 20, three single-phase circuits are activated by a temperature controller through an external contactor.

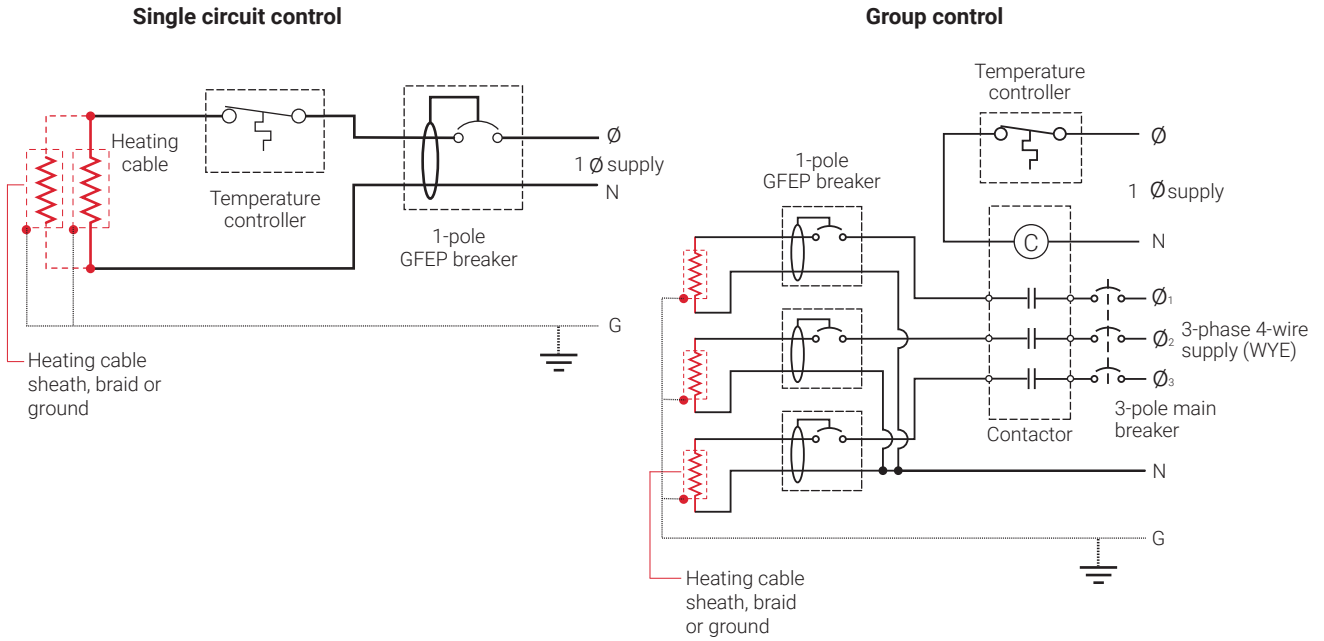

Fig. 20 Single circuit and group control

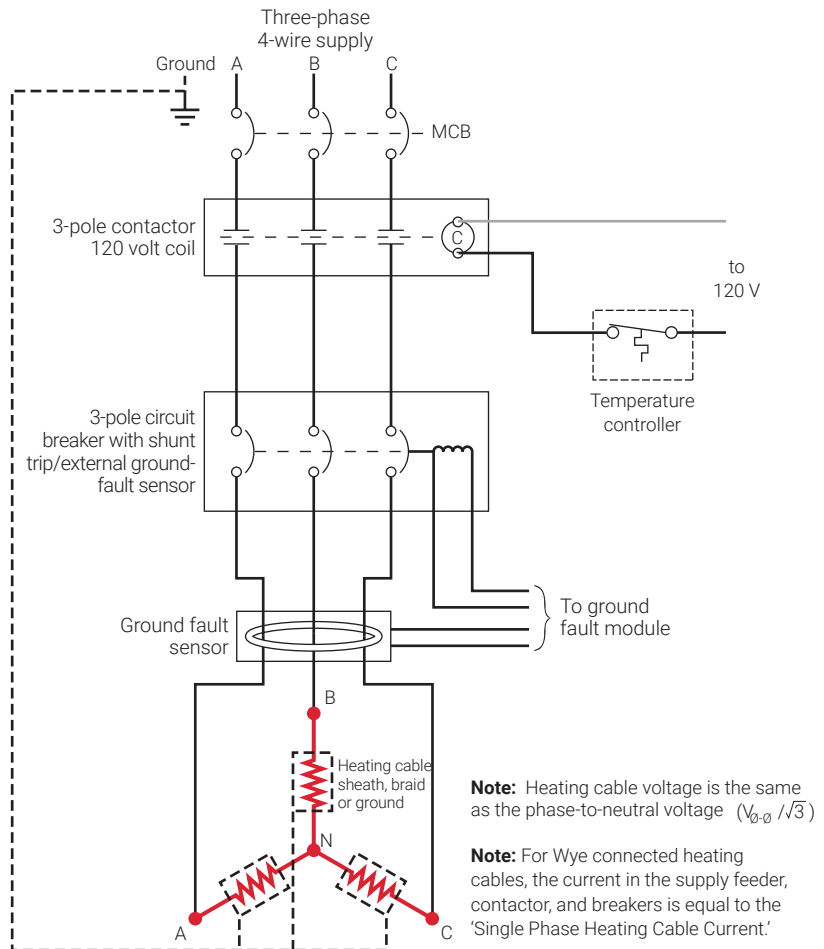

Fig. 21 Typical three-phase wye connected cables with temperature controller and contactor

Large systems with many circuits should use an HTPG power distribution panel. The HTPG is a dedicated power-distribution, control, ground-fault protection, monitoring, and alarm panel for freeze protection and broad temperature-maintenance heat-tracing applications. This enclosure contains an assembled circuit-breaker panelboard. Panels are equipped with ground-fault circuit breakers with or without alarm contacts. The group control package allows the system to operate automatically in conjunction with a temperature control system.

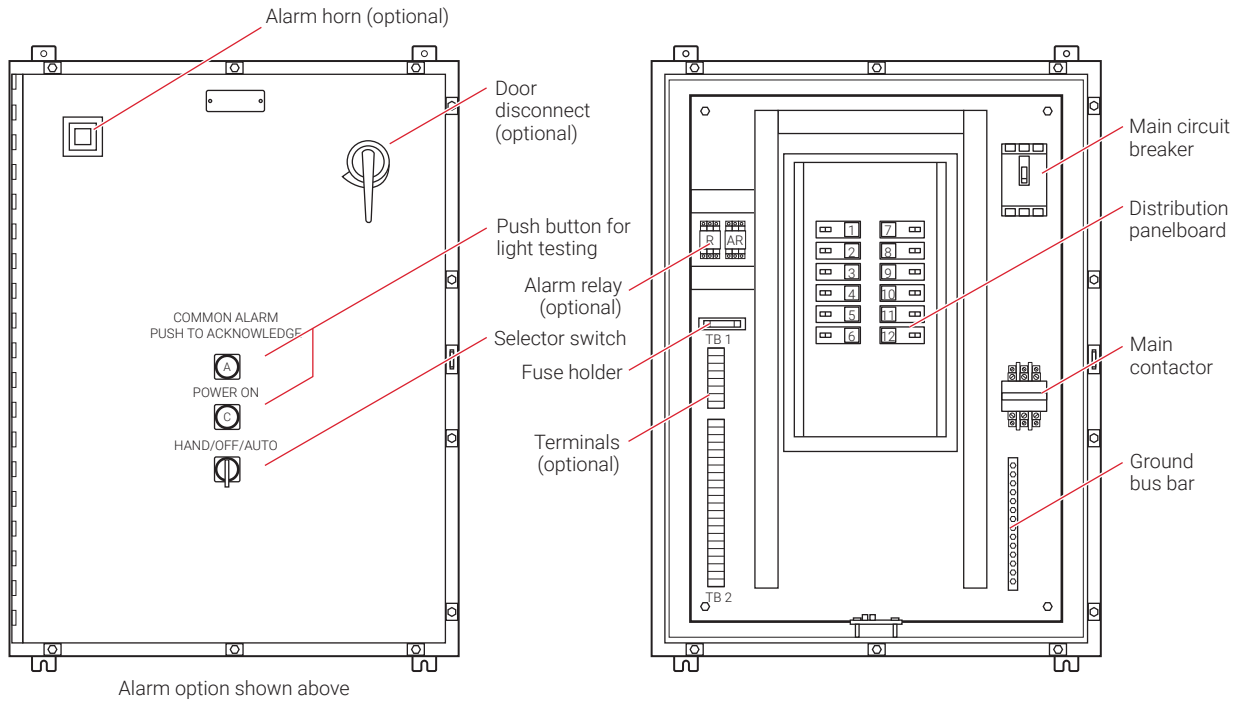

Fig. 22 HTPG power distribution panel

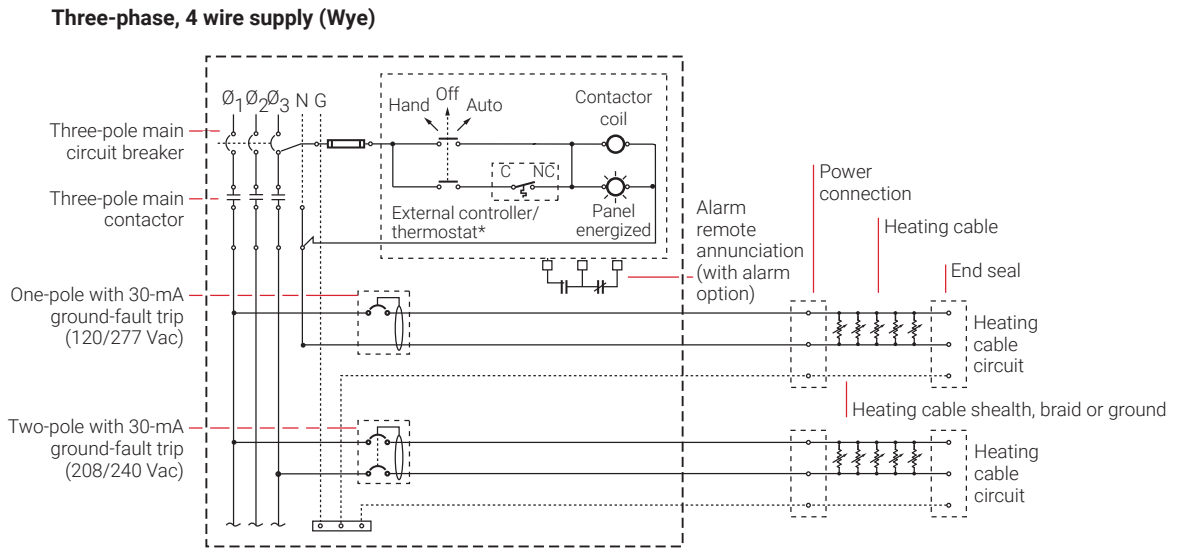



Fig. 23 Typical HTPG power schematic

Table 16 Power Distribution

	Catalog number	Description
Power distribution and control panels		
	HTPG	Heat-tracing power distribution panel with ground-fault and monitoring for group control.

Freezer Frost Heave Prevention System Design Steps (Embedded)
1. Determine the freezer configuration
2. Determine heat loss and freezer load
3. Select the heating cable, layout and length
4. Determine the heating cable spacing
5. Determine the electrical parameters
6. Select the accessories
7. Select the control system
8. Select the power distribution system
9. Complete the Bill of Materials

Step 9 Complete the Bill of Materials

If you used the Design Worksheet to document all your design parameters, you should have all the details necessary complete your Bill of Materials.

RAYSOL AND MI HEATING CABLE IN CONDUIT FREEZER FROST HEAVE PREVENTION DESIGN WORKSHEET

Step 1 Determine the freezer configuration (RaySol and MI heating cable systems)

Determine freezer area (from scale drawing)	Determine freezer operating temperature	Record insulation R-value	Supply voltage
$\frac{\text{Side A (length) (ft/m)}}{\text{Side B (width) (ft/m)}} \times \text{Side B (width) (ft/m)} = \text{Freezer area (ft}^2\text{/m}^2\text{)}$	_____ °F/°C	_____ ft ² ·°F·hr/Btu	_____ Volts

Example: RaySol and MI heating cables

$\frac{80 \text{ ft}}{40 \text{ ft}} \times 40 \text{ ft} = 3200 \text{ ft}^2$	-20°F	R-40 (40 ft ² ·°F·hr/Btu)	208 Volts
$\frac{\text{Side A (length) (ft)}}{\text{Side B (width) (ft)}} \times \text{Side B (width) (ft)} = \text{Freezer area (ft}^2\text{)}$			

Step 2 Select the heating cable

RaySol heating cable	MI heating cable
Supply voltage <input type="checkbox"/> 120 V <input type="checkbox"/> 208 V <input type="checkbox"/> 240 V <input type="checkbox"/> 277 V Catalog number: _____	Supply voltage <input type="checkbox"/> 120 V <input type="checkbox"/> 208 V <input type="checkbox"/> 277 V Freezer side A length (ft/m): _____ Catalog number: _____ Power output (W): _____
Example: RaySol heating cable Supply voltage ✓ 208 V Catalog number: RaySol-2	Supply voltage ✓ 208 V Freezer side A length: 80 ft Catalog number: FFHPC30 Power output: 475 W

Step 3 Determine the heating cable conduit spacing and freezer load (RaySol and MI heating cable systems)

Based on the insulation R-value and freezer operating temperature you recorded in Step 1, use Table 4 to select the following:

Conduit spacing (in/cm) _____ Freezer load (W/ft²) (W/m²) _____

Example: For RaySol and MI heating cables

Conduit spacing: **96 in** Freezer load: **0.5 W/ft²**

Step 4 Determine the heating cable layout and length

RaySol heating cable in conduit

1. Estimate the number of conduit runs

Imperial

$$\left(\frac{\text{Side B (ft)} \times 12}{\text{Conduit spacing (in)}} \right) = \frac{\text{Estimated number of conduit runs}}$$

Metric

$$\left(\frac{\text{Side B (m)} \times 100}{\text{Conduit spacing (cm)}} \right) = \frac{\text{Estimated number of conduit runs}}$$

If necessary, round to the next whole number

Example: RaySol heating cable

$$\left(\frac{40 \text{ ft} \times 12}{96 \text{ in}} \right) = \frac{5}{\text{Estimated number of conduit runs}}$$

2. Estimate the heating cable length required for conduit runs

$$\frac{\text{Side A (ft/m)}}{\text{Number of conduit runs}} = \frac{\text{Heating cable length required (ft/m)}}$$

Example: RaySol heating cable

$$\frac{80 \text{ ft}}{5} = \frac{400 \text{ ft}}{\text{Heating cable length required (ft)}}$$

3. Determine the maximum circuit length (see Table 5)

$$\frac{\text{Heating cable length required (ft/m)}}{\text{Supply voltage (V)}} \rightarrow \frac{\text{Maximum circuit length (ft/m)}}$$

Is the heating cable length required > the maximum circuit length?

- No – One circuit is sufficient
- Yes – Multiple circuits are required

Number of circuits Power supply

Example: RaySol heating cable

$$\frac{400 \text{ ft}}{208 \text{ V}} \rightarrow \frac{410 \text{ ft}}{\text{Maximum circuit length (ft)}}$$

Is the heating cable length required > the maximum circuit length?

✓ No – One circuit is sufficient

1 One 20 A circuit breaker

Number of circuits Power supply

4. Determine layout

Is Side A x 2 ≤ to the maximum circuit length?

- Yes – Conduit can be looped in hairpin configuration
 - Odd number of conduit runs – One conduit run will be straight
 - Even number of conduit runs – All conduit run are looped in hairpin configuration
- No – Use a straight run layout

MI heating cable in conduit

1. Estimate the number of conduit runs

Imperial

$$\left(\frac{\text{Side B (ft)} \times 12}{\text{Conduit spacing (in)}} \right) = \frac{\text{Estimated number of conduit runs}}$$

Metric

$$\left(\frac{\text{Side B (m)} \times 100}{\text{Conduit spacing (cm)}} \right) = \frac{\text{Estimated number of conduit runs}}$$

If necessary, round to the next whole number

Example: MI heating cable

$$\left(\frac{40 \text{ ft} \times 12}{96 \text{ in}} \right) = \frac{5}{\text{Estimated number of conduit runs}}$$

2. Determine the number of MI heating cables

$$\frac{\text{Number of conduit runs}}{\text{Number of heating cables required}}$$

Example: MI heating cable

$$\frac{5}{\text{Number of conduit runs}} = \frac{5}{\text{Number of heating cables required}}$$

Example: RaySol heating cable

Is Side A x 2 ≤ to the maximum circuit length?

✓ Yes – Conduit can be looped in hairpin configuration

✓ Odd number of conduit runs – One conduit run will be straight

Layout: Run in two hairpin loops and one straight run

5. Determine end allowances and connection kit allowances (see Table 6) and total heating cable length required.

Determine end allowances

_____ x 8 ft = _____

Number of hairpin conduits

_____ x 8 ft = _____

Number of straight run conduits

Heating cable length for end allowances _____

Example: RaySol heating cable

2 _____ x 8 ft = **16 ft** _____

Number of hairpin conduits

1 _____ x 8 ft = **8 ft** _____

Number of straight run conduits

Heating cable length for end allowances **24 ft** _____

Determine connection kit allowances

_____ x 4 ft = _____

Number of FTC-XC kits for hairpin conduits

_____ x 4 ft = _____

Number of FTC-XC kits for straight run conduits

Heating cable length for connection kit allowances _____

Example: RaySol heating cable

2 _____ x 4 ft = **8 ft** _____

Number of FTC-XC kits for hairpin conduits

1 _____ x 4 ft = **4 ft** _____

Number of FTC-XC kits for straight run conduits

Heating cable length for connection kit allowances **12 ft** _____

Determine total heating cable length required for conduit runs and allowances

_____ +	_____ +	_____ =	_____
Heating cable length for conduit runs (ft/m)	Heating cable length for end allowances (ft/m)	Heating cable length for connection kit allowances (ft/m)	Total heating cable length required (ft/m)

Example: RaySol heating cable

400 ft _____ +	24 ft _____ +	12 ft _____ =	436 ft _____
Heating cable length for conduit runs (ft)	Heating cable length for end allowances (ft)	Heating cable length for connection kit allowances (ft)	Total heating cable length required (ft)

Step 5 Determine the electrical parameters

RaySol heating cable in conduit

Determine number of circuits

Circuit breaker rating (A): _____ (from Step 4, Table 5)

Number of circuits: _____ (from Step 4)

Calculate circuit breaker load

$$\left(\frac{\text{Circuit breaker rating (A)}}{\text{Circuit breaker rating (A)}} \times 0.8 \times \frac{\text{Supply voltage}}{\text{Supply voltage}} \right) / 1000 = \text{Circuit breaker load (kW)}$$

MI heating cable in conduit

Determine circuit breaker rating and number of circuits

Circuit breaker rating (A): _____

Number of circuits: _____

Calculate circuit breaker rating and number of circuits

$$\left(\frac{\text{Total current (A)}}{\text{Total current (A)}} \times 1.25 \right) = \text{Minimum circuit breaker rating (A)*} = \text{Circuit breaker rating (A)}$$

↓

$$= \text{Number of circuits}$$

Example: RaySol heating cable

$$\left(\frac{20 \text{ A}}{\text{Circuit breaker rating (A)}} \times 0.8 \times \frac{208 \text{ V}}{\text{Supply voltage}} \right) / 1000 = \text{3.3 kW Circuit breaker load}$$

*Use next largest available circuit breaker or break into smaller circuits

Example: MI heating cable

$$\left(\frac{11.5 \text{ A}}{\text{Total current (A)}} \times 1.25 \right) = \text{14.4 A Minimum circuit breaker rating (A)*} = \text{15 A Circuit breaker rating (A)}$$

↓

$$= \text{1 Number of circuits}$$

*Use next largest available circuit breaker or break into smaller circuits

Calculate total transformer load

$$\text{CBL}_1 + \text{CBL}_2 + \text{CBL}_3 \dots + \text{CBL}_N = \text{Total transformer load (kW)}$$

Calculate total transformer load

$$\left(\frac{\text{Cable}_1 \text{ (W)} + \text{Cable}_2 \text{ (W)} + \text{Cable}_3 \text{ (W)} \dots + \text{Cable}_N \text{ (W)}}{\text{Cable}_1 \text{ (W)} + \text{Cable}_2 \text{ (W)} + \text{Cable}_3 \text{ (W)} \dots + \text{Cable}_N \text{ (W)}} \right) / 1000 = \text{Total transformer load (kW)}$$

Example: RaySol heating cable

$$\frac{3.3 \text{ kW}}{\text{CBL}_1} = \text{3.3 kW Total transformer load (kW)}$$

Example: MI heating cable

$$\left(\frac{475 \text{ W} + 475 \text{ W} + 475 \text{ W} + 475 \text{ W} + 475 \text{ W}}{\text{Cable}_1 + \text{Cable}_2 + \text{Cable}_3 + \text{Cable}_4 + \text{Cable}_5} \right) / 1000 = \text{2.4 kW Total transformer load}$$

Step 6 Select the connection kits and accessories

Connection kits and accessories	Description	Quantity
<input type="checkbox"/> FTC-XC	Power connection and end seal	_____
<input type="checkbox"/> FTC-HST-PLUS	Low-profile splice/tee	_____
<input type="checkbox"/> RayClic-E	Extra end seal	_____
<input type="checkbox"/> MIJB-864-A	Fiberglass junction box (for MI cable only)	_____
<input type="checkbox"/> MIJB-1086-B	Fiberglass junction box (for MI cable only)	_____

Example:

<input checked="" type="checkbox"/> FTC-XC	Power connection and end seal	3	(for RaySol)
<input checked="" type="checkbox"/> MIJB-864-A	Fiberglass junction box (for MI cable only)	5	(for MI)

Step 7 Select the control system

Thermostats, controllers, and accessories	Description	Quantity
<input type="checkbox"/> ECW-GF	Electronic thermostat with 25-ft sensor	_____
<input type="checkbox"/> ECW-GF-DP	Remote display panel for ECW-GF	_____
<input type="checkbox"/> MI-GROUND-KIT	Grounding kit for nonmetallic enclosures	_____
<input type="checkbox"/> C910-485	Microprocessor-based single-point heat-trace controller	_____
<input type="checkbox"/> ACS-UIT3	ACS-30 user interface terminal	_____
<input type="checkbox"/> ACS-PCM2-5	ACS-30 power control panel	_____
<input type="checkbox"/> ProtoNode-RER	Multi-protocol gateway	_____
<input type="checkbox"/> RTD10CS	Resistance temperature device for C910-485 & ACS-30	_____
<input type="checkbox"/> RTD-200	Resistance temperature device for C910-485 & ACS-30	_____
<input type="checkbox"/> RTD50CS	Resistance temperature device for C910-485 & ACS-30	_____

Example:

C910-485 Microprocessor-based single-point heat-trace controller 1

Step 8 Select the power distribution

Power distribution	Description	Quantity
<input type="checkbox"/> HTPG	Heat-tracing power distribution panel for group control	_____

Step 9 Complete the Bill of Materials

Use the information recorded in this worksheet to complete the Bill of Materials.

MI CABLES DIRECTLY EMBEDDED FREEZER FROST HEAVE PREVENTION DESIGN WORKSHEET

Step 1 Determine the freezer configuration

Determine freezer area (from scale drawing)	Determine freezer operating temperature	Record insulation R-value	Supply voltage	Phase
$\frac{\text{Side A (length) (ft/m)}}{\text{Side A (length) (ft/m)}} \times \frac{\text{Side B (width) (ft/m)}}{\text{Side B (width) (ft/m)}} = \frac{\text{Freezer area (ft}^2\text{/m}^2\text{)}}{\text{Freezer area (ft}^2\text{/m}^2\text{)}}$	_____ °F/°C	_____ ft ² ·°F·hr/Btu	_____ Volts	_____ Phase
Example: $\frac{40 \text{ ft}}{\text{Side A (length) (ft)}} \times \frac{20 \text{ ft}}{\text{Side B (width) (ft)}} = \frac{800 \text{ ft}^2}{\text{Freezer area (ft}^2\text{)}}$	-30°F	R-20 (20 ft²·°F·hr/Btu)	208 V	Single phase

Step 2 Determine the heat loss and freezer load

Based on the insulation R-value and freezer operating temperature you recorded in Step 1, use Table 11 to select the following:

Design power _____ W/ft² (W/m²) Freezer load _____ W/ft² (W/m²)

Example: $\frac{1.1 \text{ W/ft}^2}{\text{Design power}}$	$\frac{1.1 \text{ W/ft}^2}{\text{Freezer load}}$
---	--

Step 3 Select the heating cable, layout and length

Use Table 12 and Table 13 to select your heating cable and determine your cable wattage.

Heating cable voltage

- 120 V
- 208 V
- 240 V
- 277 V
- 347 V

Design power (W/ft ²) / (W/m ²)	Area (ft ² /m ²)	Power required (W)	Catalog number	Cable wattage (W)	Heated length (ft)	Quantity
_____ x _____ = _____	_____	_____	_____	_____	_____	_____
Example:						
✓ 208 V						
$\frac{1.1 \text{ W/ft}^2}{\text{Design power (W/ft}^2\text{)}} \times \frac{800 \text{ ft}^2}{\text{Area (ft}^2\text{)}} = \frac{880 \text{ W}}{\text{Power required (W)}}$						
			SUB19	885 W	245 ft	1

Step 4 Determine the heating cable spacing

Imperial

Metric

$$\frac{\text{Area (ft}^2\text{)}}{\text{Heated length (ft)}} \times 12 = \frac{\text{Cable spacing (in)}}{\text{Area (m}^2\text{)}} \times 100 = \frac{\text{Cable spacing (cm)}}{\text{Heated length (m)}}$$

If necessary, round to whole number.

Example:

$$\frac{800 \text{ ft}^2}{245 \text{ ft}} \times 12 = \frac{39.2 \text{ in rounded to 39 in}}{\text{Cable spacing (in)}}$$

Step 5 Determine the electrical parameters

Determine circuit breaker rating and number of circuits

Circuit breaker rating (A): _____

Number of circuits: _____

Calculate circuit breaker rating and number of circuits

$$\left(\frac{\text{Total current (A)}}{\text{Total current (A)}} \times 1.25 \right) = \frac{\text{Minimum circuit breaker rating (A)*}}{\text{Minimum circuit breaker rating (A)*}} = \frac{\text{Circuit breaker rating (A)}}{\text{Circuit breaker rating (A)}} = \frac{\text{Number of circuits}}{\text{Number of circuits}}$$

*Use next largest available circuit breaker or break into smaller circuits

Example

$$\left(\frac{4.3 \text{ A}}{\text{Total current (A)}} \times 1.25 \right) = \frac{5.4 \text{ A}}{\text{Minimum circuit breaker rating (A)*}} = \frac{15 \text{ A}}{\text{Circuit breaker rating (A)}} = \frac{1}{\text{Number of circuits}}$$

*Use next largest available circuit breaker or break into smaller circuits

Calculate total transformer load

$$\left(\frac{\text{Cable}_1 \text{ (W)}}{\text{Cable}_1 \text{ (W)}} + \frac{\text{Cable}_2 \text{ (W)}}{\text{Cable}_2 \text{ (W)}} + \frac{\text{Cable}_3 \text{ (W)...}}{\text{Cable}_3 \text{ (W)...}} + \frac{\text{Cable}_N \text{ (W)}}{\text{Cable}_N \text{ (W)}} \right) / 1000 = \frac{\text{Total transformer load (kW)}}{\text{Total transformer load (kW)}}$$

Example

$$\left(\frac{885 \text{ W}}{\text{Cable}_1} \right) / 1000 \rightarrow = \frac{0.9 \text{ kW}}{\text{Total transformer load}}$$

Step 6 Select the accessories

Accessory	Description	Quantity
<input type="checkbox"/> MIJB-864-A	Fiberglass junction box (for MI cable only)	_____
<input type="checkbox"/> MIJB-1086-B	Fiberglass junction box (for MI cable only)	_____

Example:

MIJB-864-A Fiberglass junction box (for MI cable only) 1

Step 7 Select the control system

Thermostats, controllers, and accessories	Description	Quantity
<input type="checkbox"/> ECW-GF	Electronic thermostat with 25-ft sensor	_____
<input type="checkbox"/> ECW-GF-DP	Remote display panel for ECW-GF	_____
<input type="checkbox"/> MI-GROUND-KIT	Grounding kit for nonmetallic enclosures	_____
<input type="checkbox"/> C910-485	Microprocessor-based single-point heat-trace controller	_____
<input type="checkbox"/> ACS-UIT3	ACS-30 user interface terminal	_____
<input type="checkbox"/> ACS-PCM2-5	ACS-30 power control panel	_____
<input type="checkbox"/> ProtoNode-RER	Multi-protocol gateway	_____
<input type="checkbox"/> RTD10CS	Resistance temperature device for C910-485 & ACS-30	_____
<input type="checkbox"/> RTD-200	Resistance temperature device for C910-485 & ACS-30	_____
<input type="checkbox"/> RTD50CS	Resistance temperature device for C910-485 & ACS-30	_____

Example:

✓ C910-485 Microprocessor-based single-point heat-trace controller 1

Step 8 Select the power distribution

Power distribution	Description	Quantity
<input type="checkbox"/> HTPG	Heat-tracing power distribution panel for group control	_____

Step 9 Complete the Bill of Materials

Use the information recorded in this worksheet to complete the Bill of Materials.

North America

Tel +1.800.545.6258
info@chemelex.com



Raychem Tracer Pyrotenax Nuheat